

LOW-POWER, LONG-RANGE WAN FOR IOT: A TECHNOLOGY OVERVIEW

RESCOM, LILLE

LAST UPDATE: 12TH JANUARY, 2015



PROF. CONGDUC PHAM
[HTTP://WWW.UNIV-PAU.FR/~CPHAM](http://www.univ-pau.fr/~cpham)
UNIVERSITÉ DE PAU, FRANCE



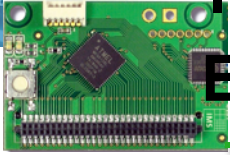

IIOT/WSN DEPLOYMENT MADE EASIER IN SINGLE-HOP MODEL

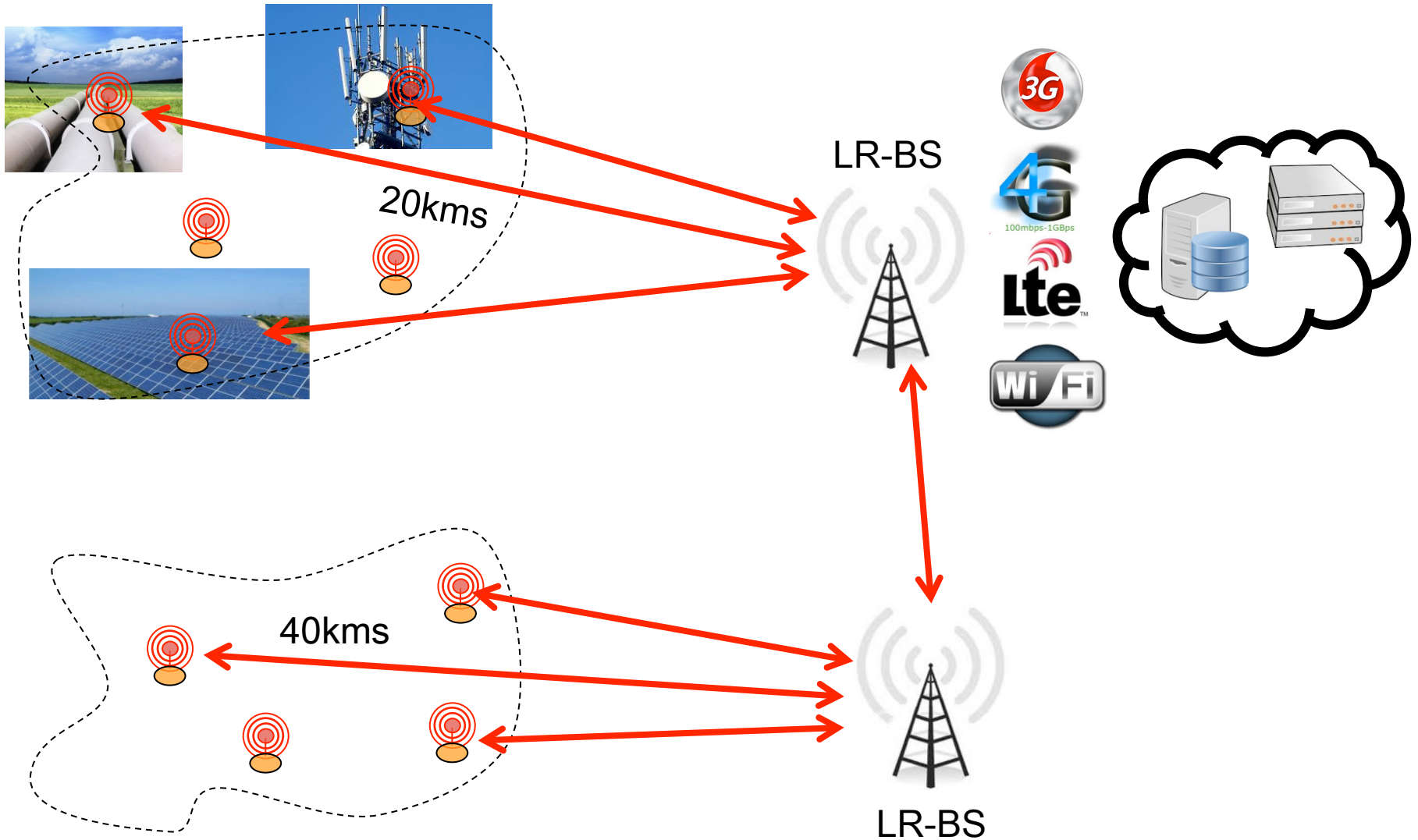

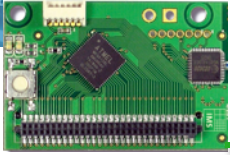

ENERGY-RANGE DILEMMA

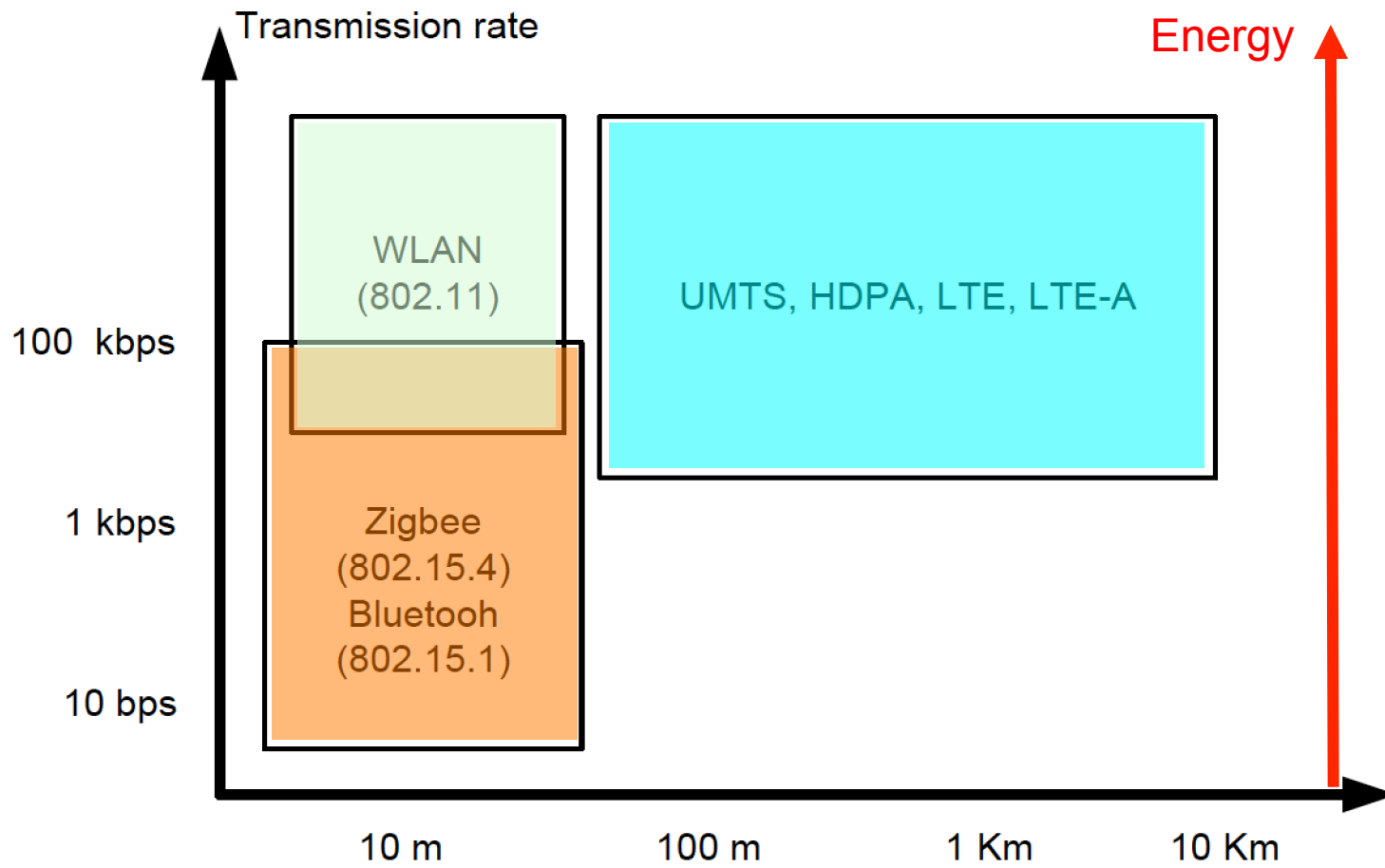

Enhanced from M. Dohler "M2M in SmartCities"

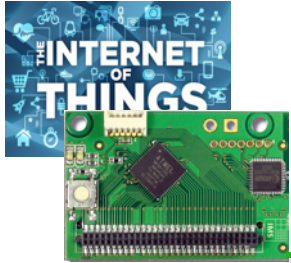

HOW COSTLY IS TRANSMISSION?

Technology	2G	3G	LAN
Range (I=Indoor, O=Outdoor)	N/A	N/A	O: 300m I: 30m
Tx current consumption	200mA- 500mA	500mA – 1000mA	50mA
Standby current	2.3mA	3.5mA	NC

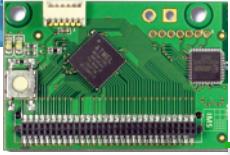

ENERGY CONSIDERATION

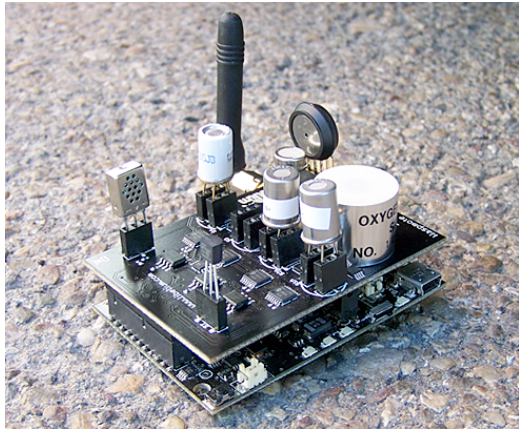

18720 JOULES

TX power: 500mA

$P = I \times V = 500 \times 3.3 = 1650\text{mW}$

$E = P \times t \rightarrow t = E/P$

11345s or 3h9mins

Technology	2G	3G	LAN
Range (I=Indoor, O=Outdoor)	N/A	N/A	O: 300m I: 30m
Tx current consumption	200mA-500mA	500mA – 1000mA	50mA
Standby current	2.3mA	3.5mA	NC

Haven't considered:

- Baseline power consumption of the sensor board
- RX consumption!
- Event capture consumption
- Event processing consumption

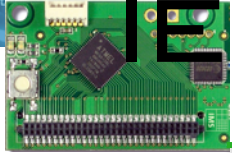
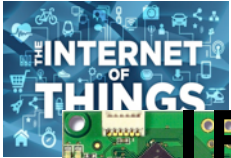

IEEE 802.15.4 IN ISM 2.4GHZ

- Low-power radio in the 2.4GHz band offering **250kbps** throughput at physical layer
- Power transmission from 1mW to 100mW for range from 100m to about 1km is LOS
- CSMA/CA
- BPSK, used as physical layer in ZigBee

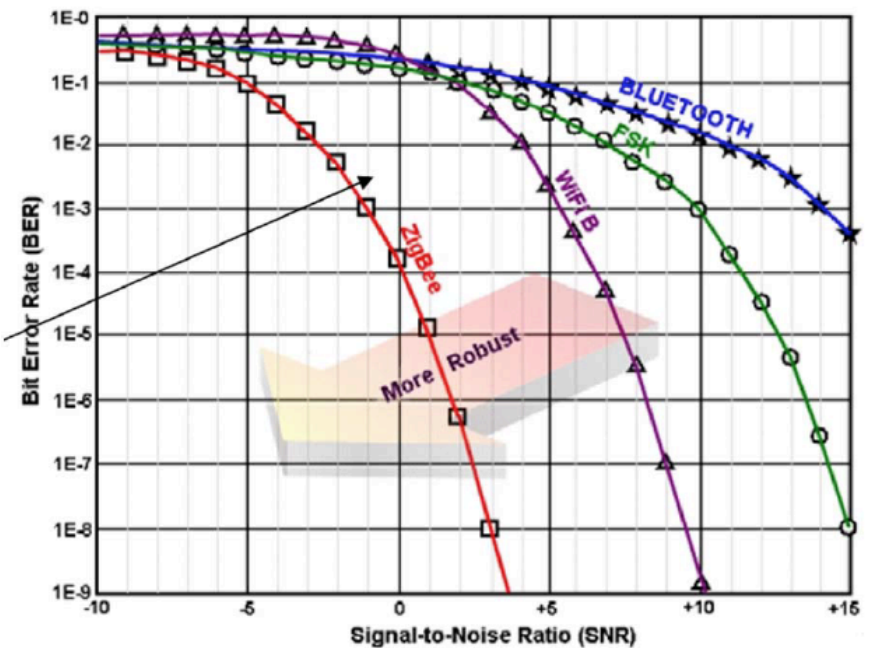

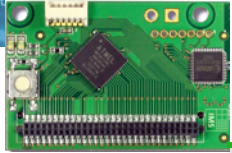
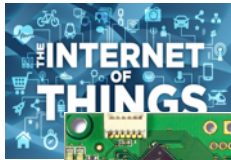

ENERGY CONSIDERATION

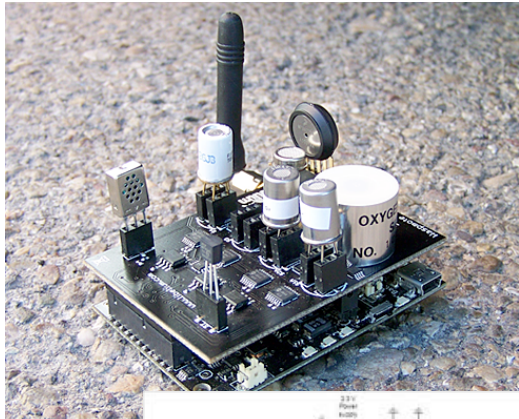

18720 JOULES

TX power 0dbm: 17.4mA

$$P = I \times V = 17.4 \times 3.3 = 57.42\text{mW}$$

$$E = P \times t \rightarrow t = E/P$$

326018s or 90.5h

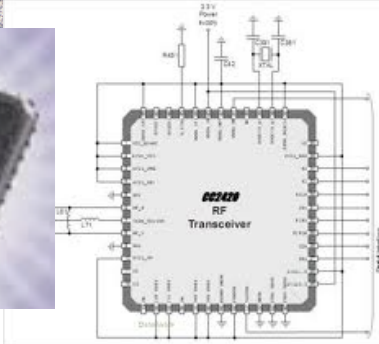

Chipcon Products
from Texas Instruments

CC2420

Parameter	Min.	Typ.	Max.	Unit	Condition / Note
Current Consumption, transmit mode:					
P = -25 dBm		8.5		mA	The output power is delivered differentially to a 50 Ω singled ended load through a balun, see also page 55.
P = -15 dBm		9.9		mA	
P = -10 dBm		11		mA	
P = -5 dBm		14		mA	
P = 0 dBm		17.4		mA	

Haven't considered:

- Baseline power consumption of the sensor board
- RX consumption: 18.8mA!
- Event capture consumption
- Event processing consumption

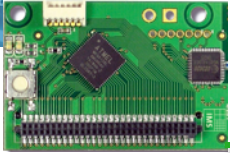

15 YEARS OF MULTI-HOP ROUTING?

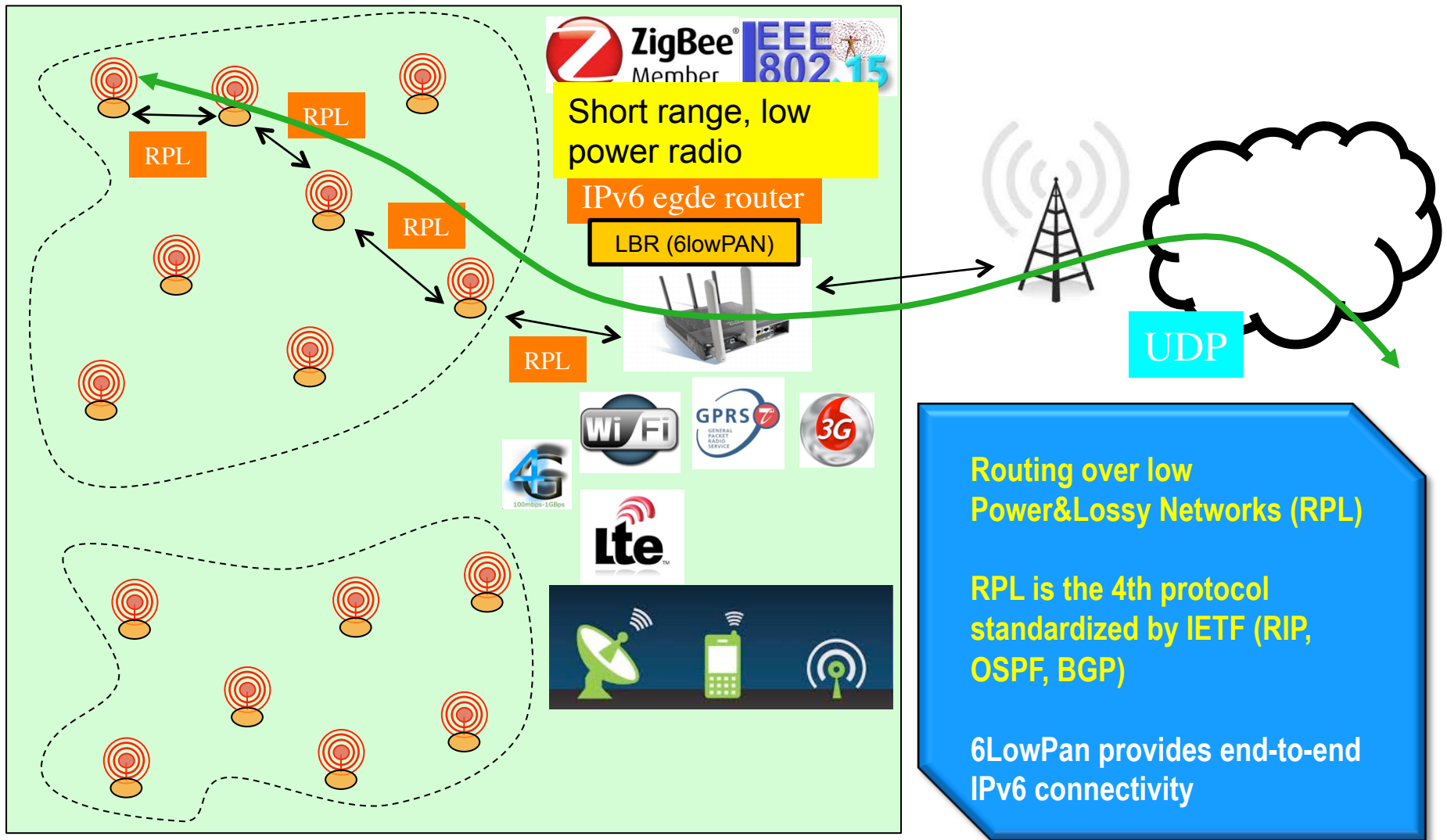

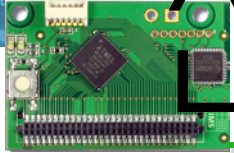

ACADEMICS VS INDUSTRIES LET'S GO BACK TO REALITY!

Millions of sensors, self-organizing, self-configuring, with QoS-based multi-path routing, mobility, and ...



500 sensors, STATIC deployment, but need to have RELIABILITY, GUARANTEED LATENCY for monitoring and alerting. MUST run for 3 YEARS. No fancy stuff! CAN I HAVE IT?

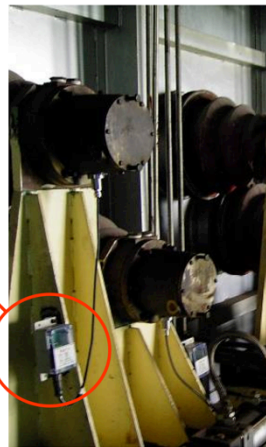
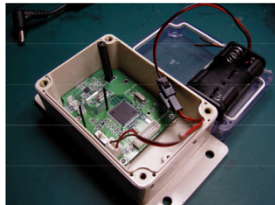

- Placement constraints
- Lifetime constraints

From Peng Zeng & Qin Wang

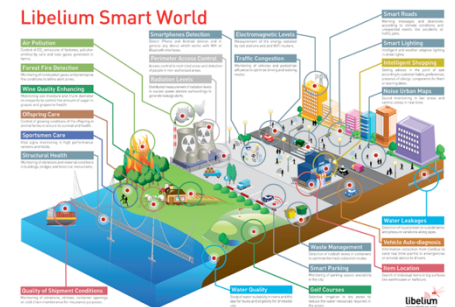

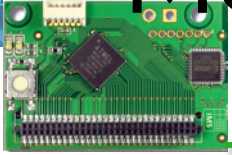

MOST TELEMETRY APPLICATIONS USE THE CELLULAR MODEL

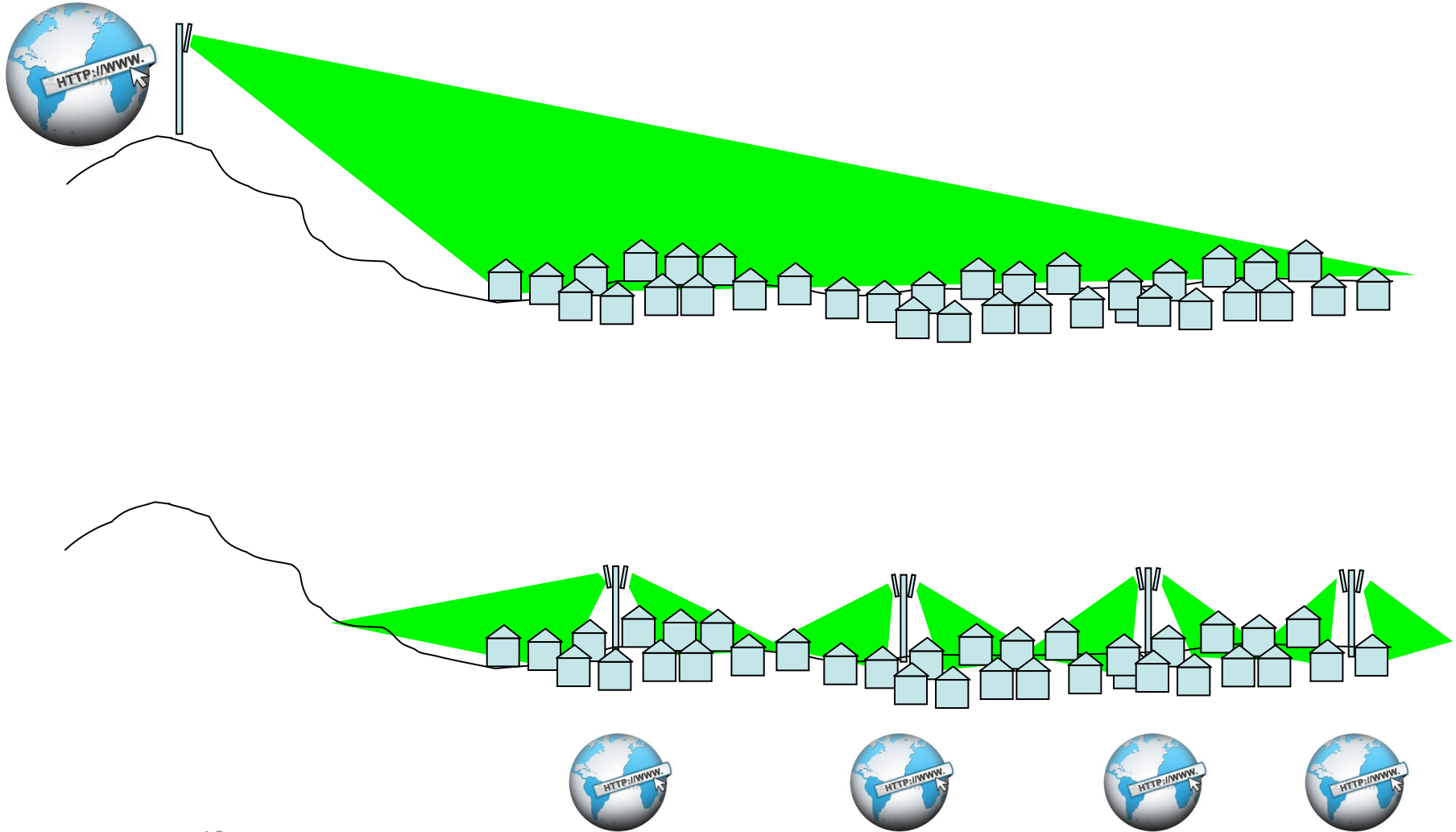



TYPICAL SCENARIOS

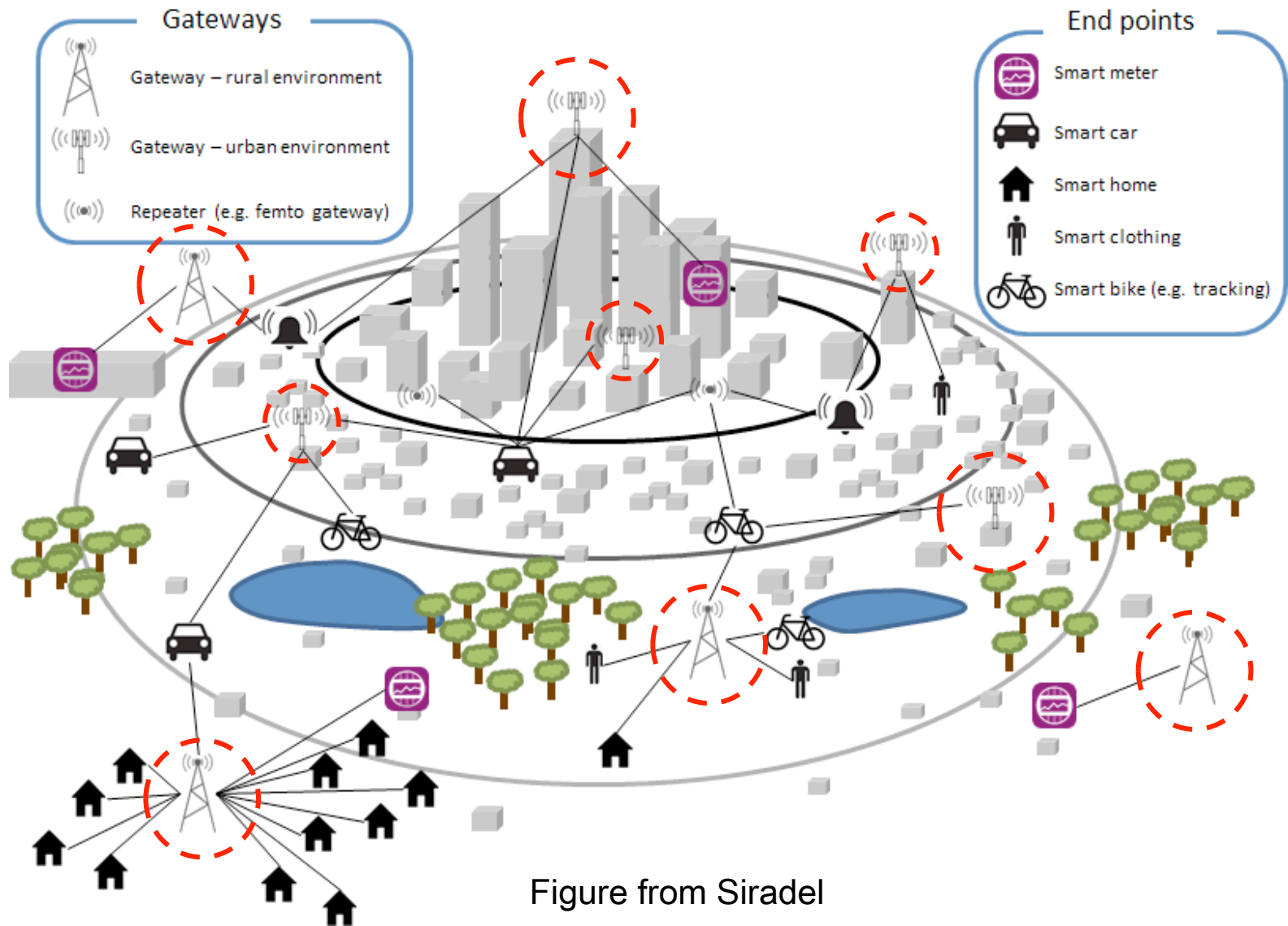
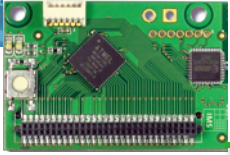
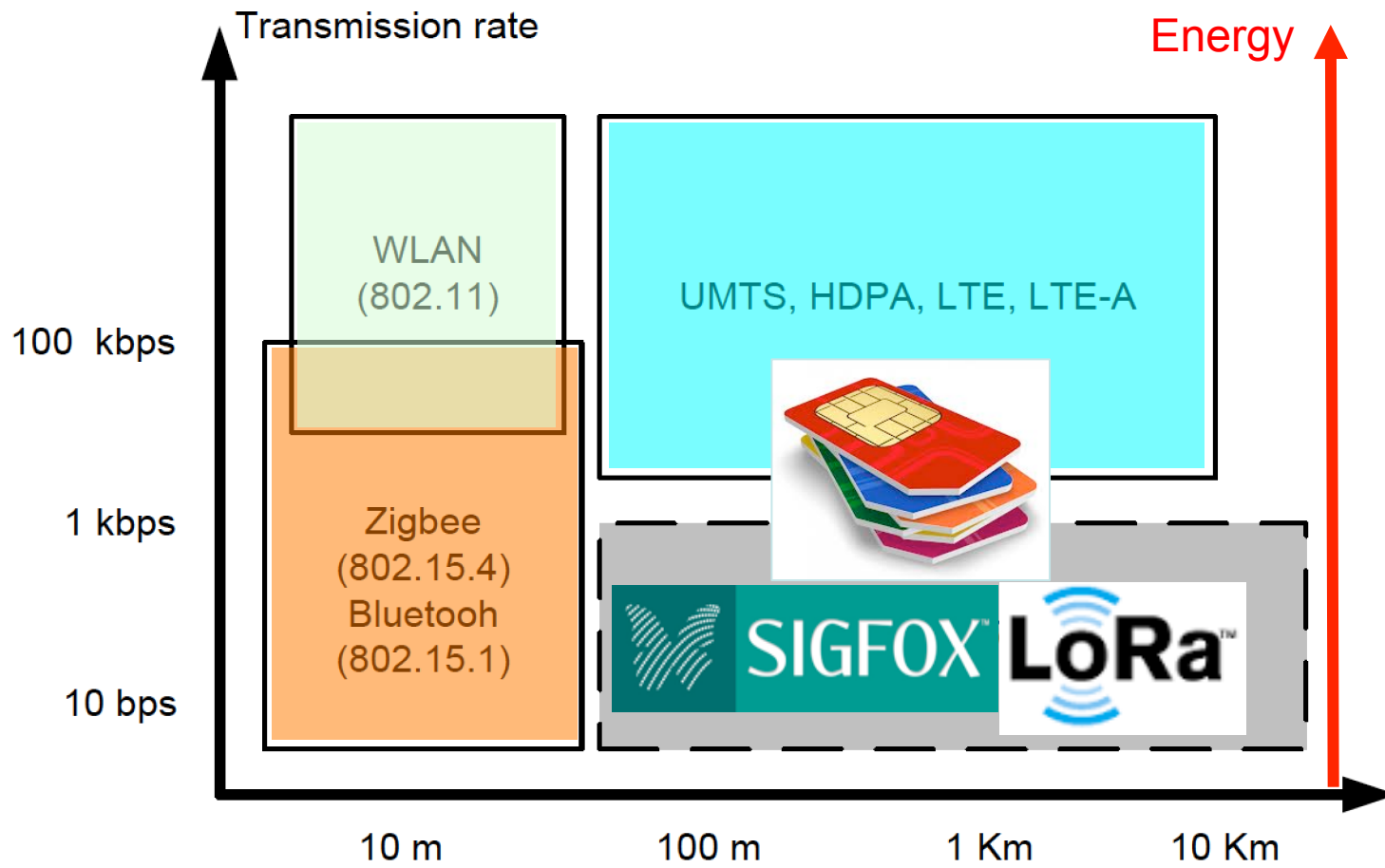
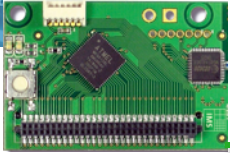

Figure from Siradel



LOW-POWER AND LONG-RANGE?





LINK BUDGET OF LPWAN

$$P_{RX} = P_{TX} + G_{TX} - L_{TX} - L_{FS} - L_M + G_{RX} - L_{RX}$$

- P_{RX} = Received power (dBm)
- P_{TX} = Sender output power (dBm)
- G_{TX} = Sender antenna gain (dBi)
- L_{TX} = Sender losses (connectors etc.)(dB)
- L_{FS} = Free space loss (dB)
- L_M = Misc. losses (multipath etc.)(dB)
- G_{RX} = Receiver antenna gain (dBi)
- L_{RX} = Receiver losses (connectors etc.)(dB)
- S_{RX} = Receiver sensitivity (dBm)

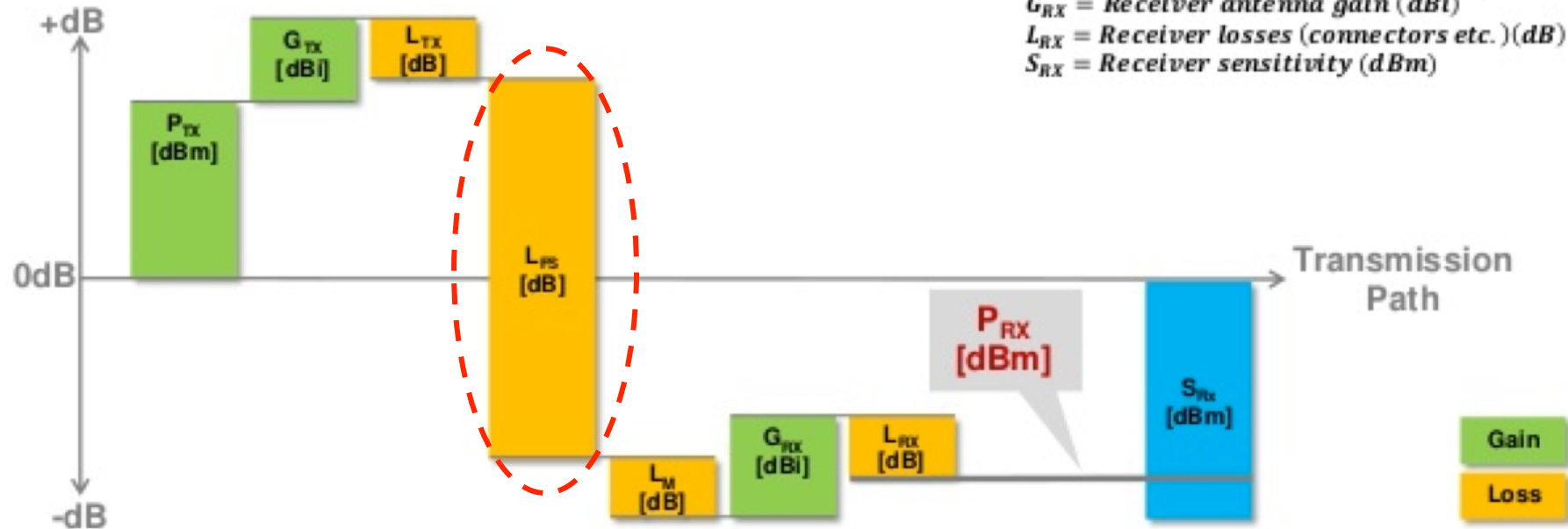

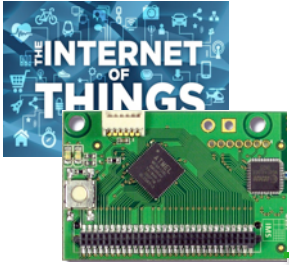

SIMPLE LOSS IN SIGNAL STRENGTH MODEL

Free Space Path Loss model

$$L_{(dB)} = 10 \log\left(\frac{P_t}{P_r}\right) = 20 \log\left(\frac{4\pi d}{\lambda}\right) = 20 \log\left(\frac{4\pi f d}{c}\right)$$

$$L_{(dB)} = 20 \log(f) + 20 \log(d) - 147,55 \text{ dB}$$

$$FSPL = \left(\frac{4\pi d}{\lambda}\right)^2 \quad FSPL = \frac{P_t}{P_r} G_t G_r$$

$$= \left(\frac{4\pi f d}{c}\right)^2$$

FSPL assume $G_t=G_r=1$

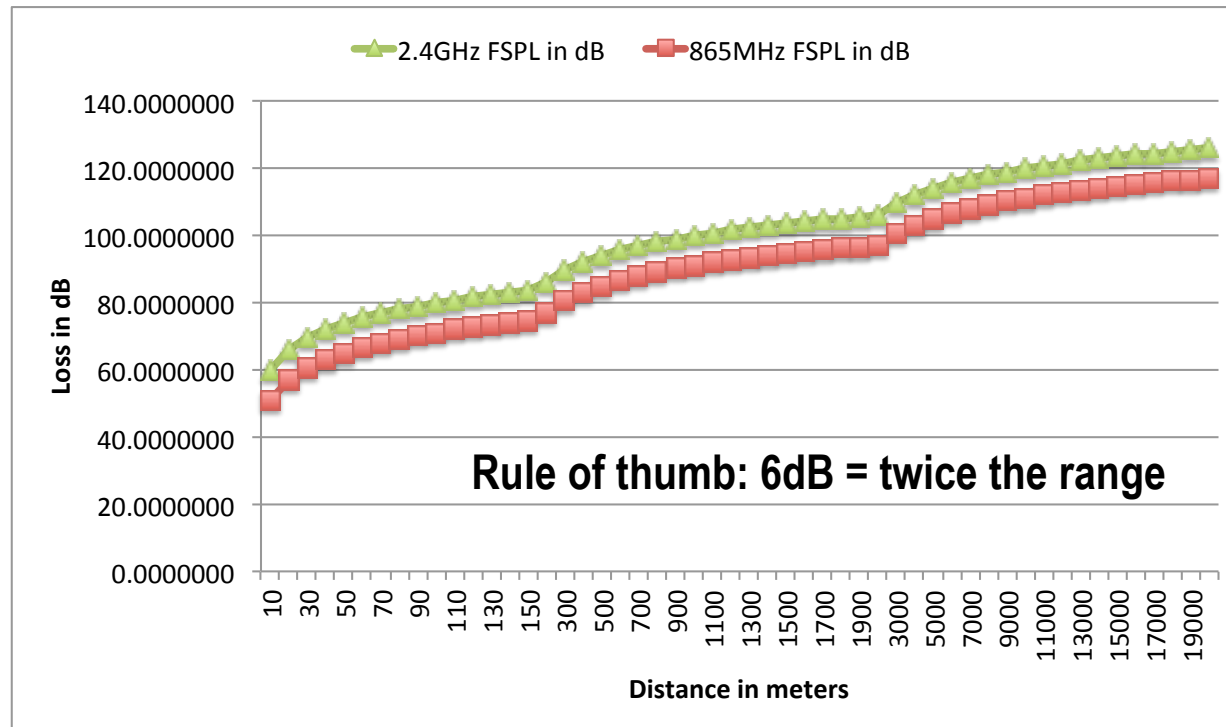

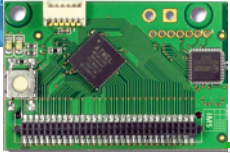

LINK BUDGET EXAMPLE

❑ **Received Power (dBm) = Transmitted Power (dBm) + Gains (dB) – Losses (dB)**

❑ Example

❑ Transmitted power is **+14dBm** (25mw)

❑ Losses (FSPL) is **120dB** (received power is 10^{12} less than transmitted power)

❑ Then Receiver Power (dBm) is **-106dBm**

❑ If you have a receiver sensitivity of -137dBm you can handle FSPL up to 151dB, i.e. 1.15×10^{15} less power than transmitted power!

❑ Rewriting the equation

❑ **Losses (dB) = Transmitted Power (dBm) - Received Power (dBm)**

❑ Losses = link budget & Received Power = max receiver sensitivity

❑ **Link budget = Transmitted Power - max receiver sensitivity**

❑ **151dB=14dBm - (-137dBm)**

dBm – power referred to 1 mW,

$$P_{\text{dBm}} = 10 \log(P/1\text{mW})$$

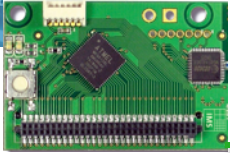

LINK BUDGET EXAMPLE

Received Power (dBm) = Transmitted Power (dBm) + Gains (dB) - Losses (dB)

Example

Transmitted power is +14dBm (25mw)

Losses (FSPL) is 100 dB (maximum distance is 1012 feet)

Then Receiver P

If you have a receiver that can handle FSPL up to 100 dB, then you can handle transmitted power up to 100 dB - 14 dB = 86 dB

Rewriting the equation

Losses (dB) = Transmitted Power (dBm) - Received Power (dBm)

Losses = link budget

Link budget = Transmitted Power - max receiver sensitivity

151dB = 14dBm - (-137dBm)

dBm - power referred to 1 mW,

$$P_{dBm} = 10 \log(P/1mW)$$

KEY PRODUCT FEATURES

LoRa™ Modem

157 dB maximum link budget

+20 dBm at 100 mW constant RF output vs. V supply

+14 dBm high efficiency PA

Programmable bit rate up to 300 kbps

High sensitivity: down to -137 dBm



INCREASING RANGE?

- ❑ Generally, robustness and sensitivity can be increased when transmitting (much) slower
- ❑ A [Sigfox message is sent relatively slowly in a very narrow band of spectrum (hence ultra-narrow-band) using Gaussian Frequency-Shift Keying modulation]
- ❑ LoRa also increases time-on-air when maximum range is needed. But LoRa uses spread spectrum instead of UNB

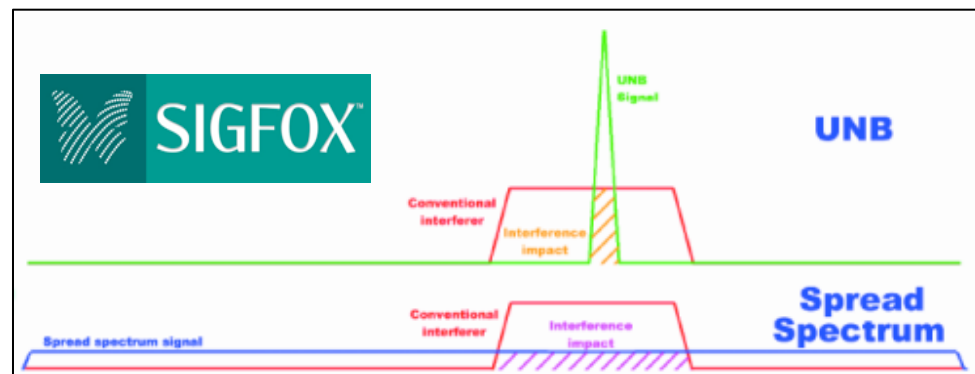



WHY THE LPWAN REVOLUTION?

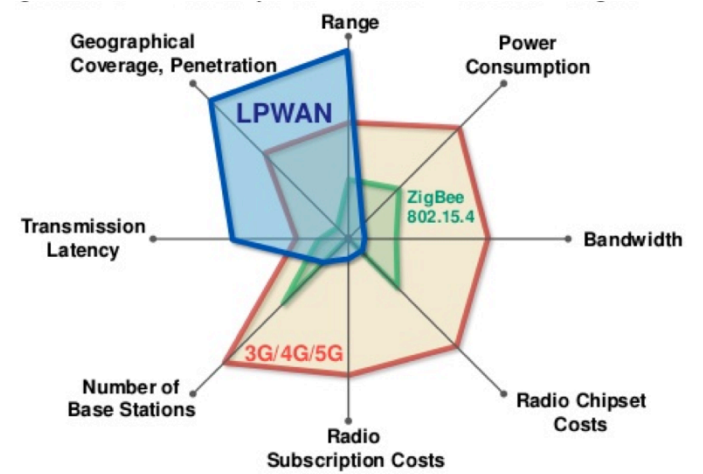
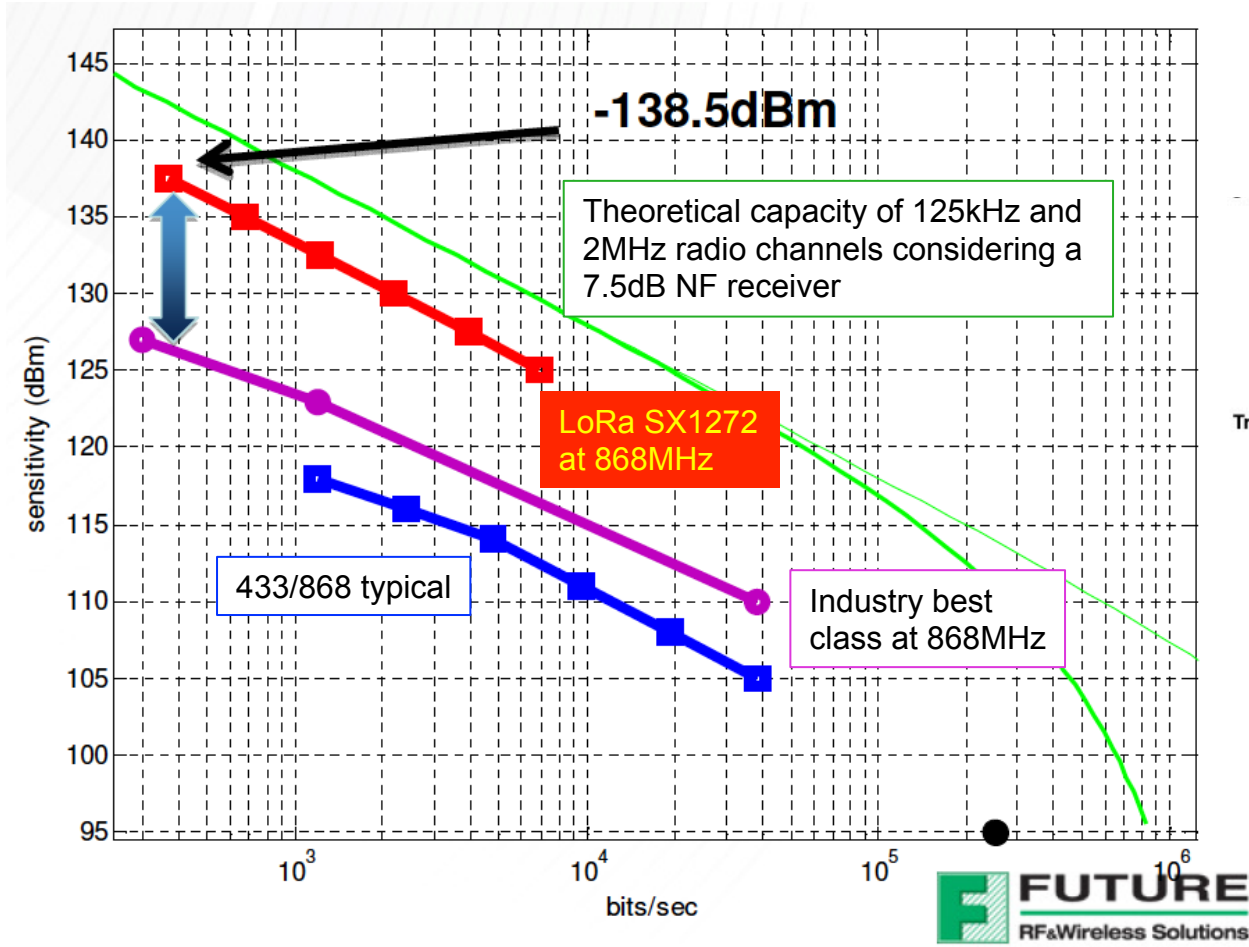

From Peter R. Egli, INDIGOO.COM

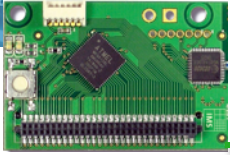

VERSATILE LPWAN!

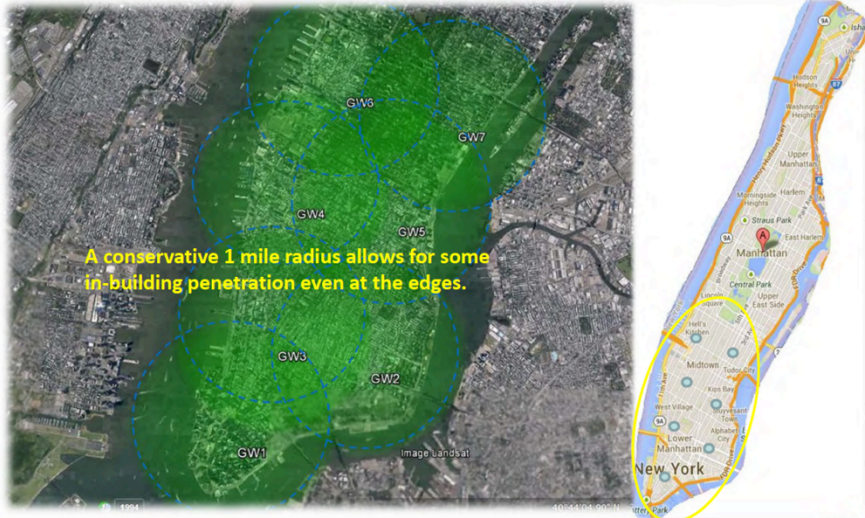

A conservative 1 mile radius allows for some in-building penetration even at the edges.

Dense urban areas

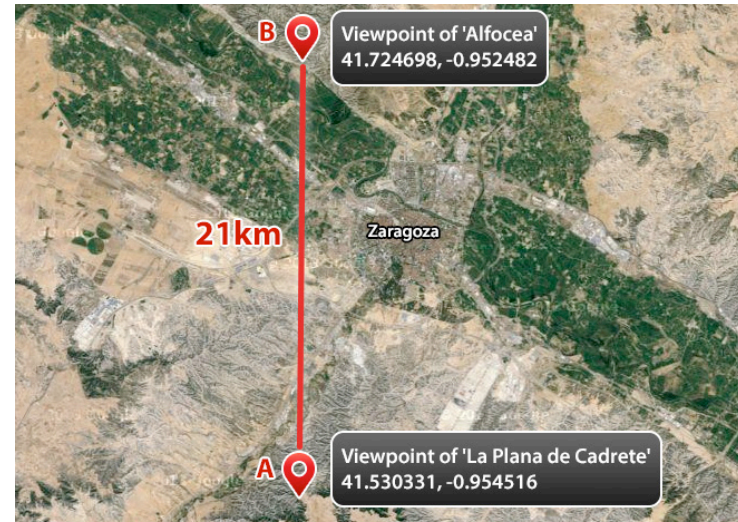

Rural areas



Indoor



Underground

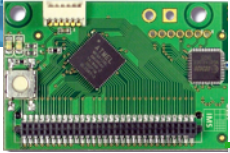

EXTREME LONG-RANGE!

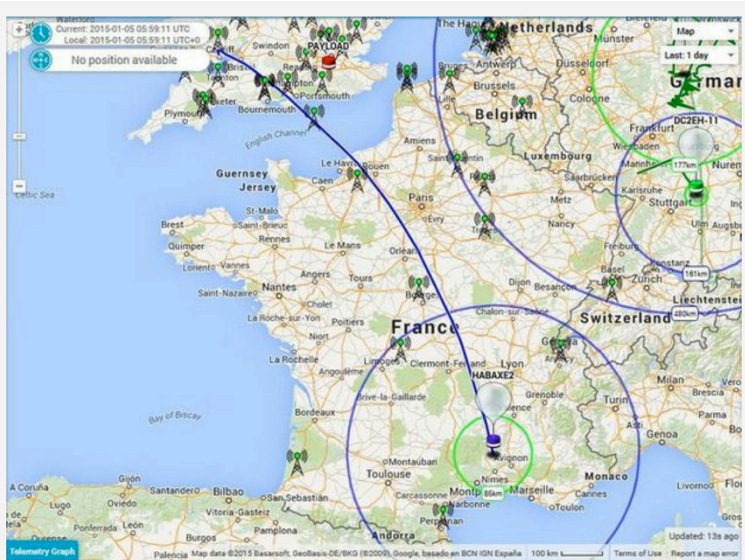

UK HAB (High Altitude Ballooning) trials gave 2 way LoRa™ coverage at up to 240 km. Lowering the data rate from 1000bps to 100bps should allow coverage all the way to the radio horizon, which is perhaps 600 km at the typical 6000-8000m soaring altitude of these balloons. Balloon tracking can be made



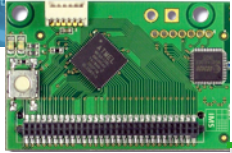

WHAT ABOUT THE THROUGHPUT?



Sigfox uses ultra-narrow band (UNB) of about 100Hz with GMSK (~BPSK)

Typical throughput is about 100bps

Devices can typically send up to 140 messages of 12-bytes per day (operator limits)

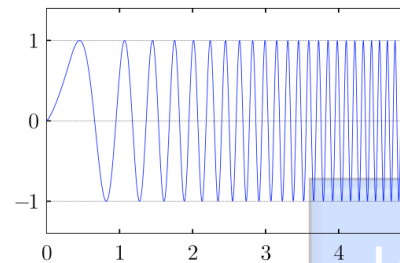

LoRa modulation is more versatile, using CSS variant

Sensitivity and throughput depend on 3 LoRa parameters: BW (bandwidth), CR (coding rate) and SF (spreading factor)

Throughput range is 240bps to 37500bps

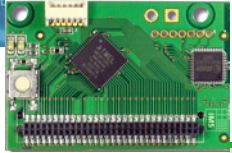

WHAT ABOUT THE THROUGHPUT?



Sigfox uses ultra-narrow band (UNB) of about 100Hz with GMSK (~

Typical t is about

Devices typically send up to 140 messages of 12-bytes per day (operator limits)

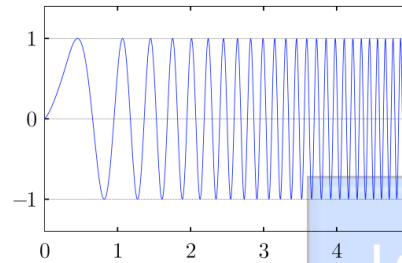

LoRa modulation is more versatile, using CSS variant

EAI Endorsed Transactions on the Internet of Things

Research Article [ICST.ORG](https://www.icst.org/)

Dedicated networks for IoT : PHY / MAC state of the art and challenges

C. Goursaud^{1,*}, J.M. Gorce¹

¹Univ Lyon, INSA Lyon, Inria, CITI, F-69621 Villeurbanne, France

(coding rate) and SF (spreading factor)

Throughput range is 240bps to 37500bps

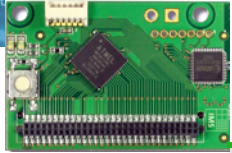

LoRA'S PARAMETERS

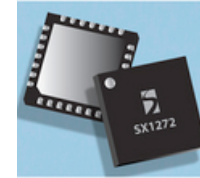

$$R_b = SF * \frac{\text{Rate Code}}{\left[\frac{2^{SF}}{BW} \right]} \text{ bits/sec}$$

Parameters

- Bandwidth: 62.5kHz, 125kHz, 250kHz, 500kHz
- Rate code: 4/4+CR (CR=1, 2, 3, 4)
- Spreading factor: 6 to 12

Sensitivity: lowest input power with acceptable link quality, typically 1% PER

SpreadingFactor (RegModemConfig2)	Spreading Factor (Chips / symbol)	LoRa Demodulator SNR
6	64	-5 dB
7	128	-7.5 dB
8	256	-10 dB
9	512	-12.5 dB
10	1024	-15 dB
11	2048	-17.5 dB
12	4096	-20 dB

Bandwidth (kHz)	Spreading Factor	Nominal Rb (bps)	Sensitivity (dBm)
125	6	9380	-122
125	12	293	-137
250	6	18750	-119
250	12	586	-134
500	6	3750	-116
500	12	1172	-131

Rule of thumb
 6dB increase = twice the range in LOS
 12dB needed for urban areas

Bandwidth (kHz)	Spreading Factor	Coding rate	Nominal Rb (bps)	Sensitivity (dBm)
125	12	4/5	293	-136
250	12	4/5	586	-133
500	12	4/5	1172	-130

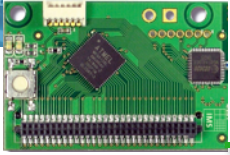

TIME ON AIR FOR VARIOUS LoRa SETTINGS

LoRa mode	BW	CR	SF	time on air in second for payload size of					
				5 bytes	55 bytes	105 bytes	155 Bytes	205 Bytes	255 Bytes
1	125	4/5	12	0.95846	2.59686	4.23526	5.87366	7.51206	9.15046
2	250	4/5	12	0.47923	1.21651	1.87187	2.52723	3.26451	3.91987
3	125	4/5	10	0.28058	0.69018	1.09978	1.50938	1.91898	2.32858
4	500	4/5	12	0.23962	0.60826	0.93594	1.26362	1.63226	1.95994
5	250	4/5	10	0.14029	0.34509	0.54989	0.75469	0.95949	1.16429
6	500	4/5	11	0.11981	0.30413	0.50893	0.69325	0.87757	1.06189
7	250	4/5	9	0.07014	0.18278	0.29542	0.40806	0.5207	0.63334
8	500	4/5	9	0.03507	0.09139	0.14771	0.20403	0.26035	0.31667
9	500	4/5	8	0.01754	0.05082	0.08154	0.11482	0.14554	0.17882
10	500	4/5	7	0.00877	0.02797	0.04589	0.06381	0.08301	0.10093

↑ Range
↓ Throughput

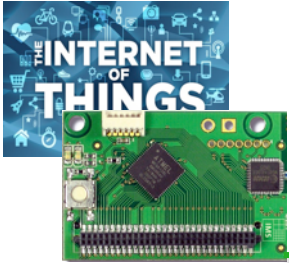

LoRa vs SigFox

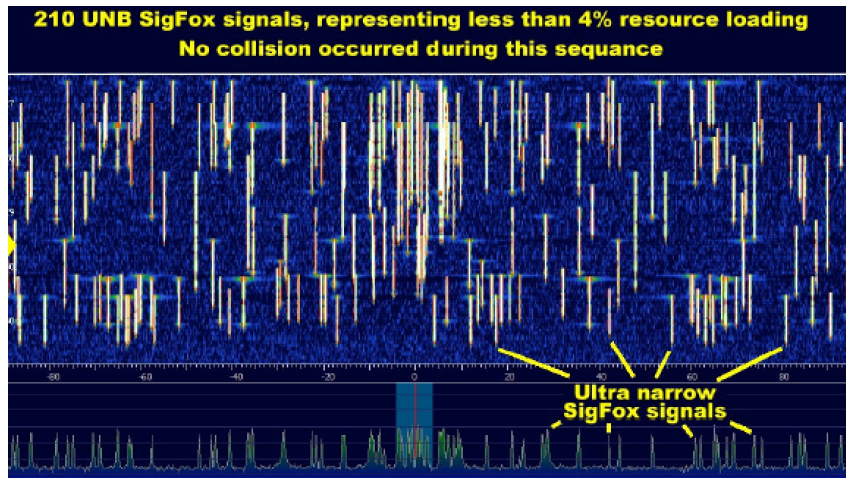
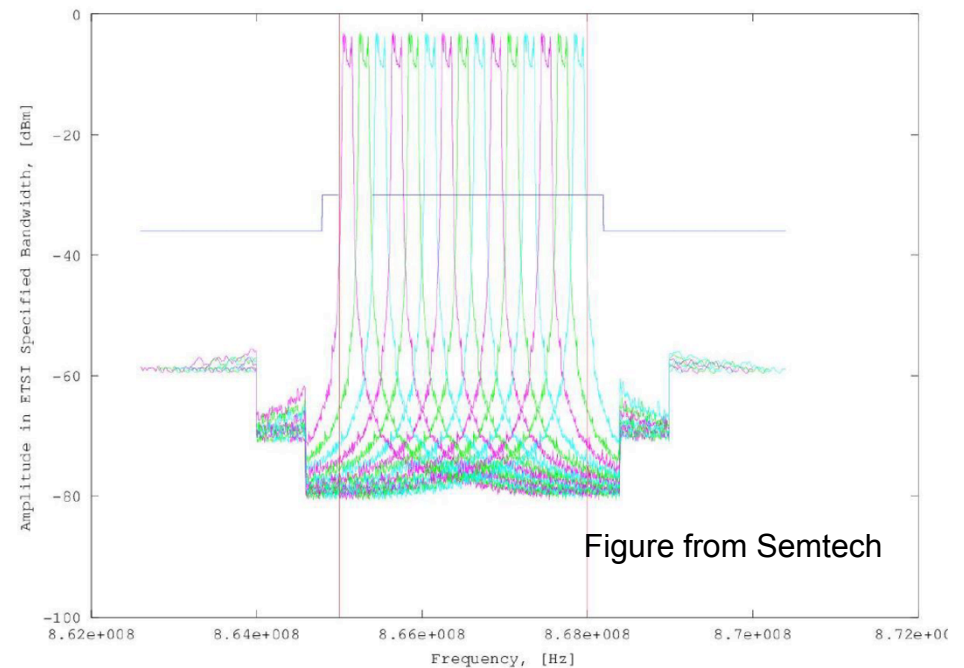

Figure from SigFox



Usual (ultra) narrow-band (UNB) vs spread spectrum (SS) arguments

UNB has lower in-band receive noise and SigFox can have more channels than LoRa

But UNB needs tighter receiver synchronization and more complex signal processing at receiver (SigFox uses advanced SDR at receiver to analyse the total band)

SS can more rapidly be saturated so LoRa may have more interference issues in dense environments

From networking guys perspective, LoRa is more versatile with possibility to build ad-hoc mesh networks

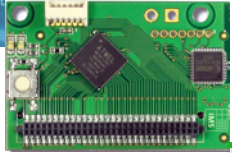

FROM SCORBIT

SIGFOX and Glen Canyon Corp. to Deploy 1 Million Smart Meters to the Internet of Things

LoRa™ technology to be integrated into FLASHNET's street lighting management solution

Tata Communication India world's largest IoT network

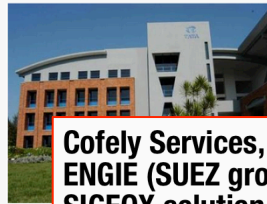

Semtech and STMicroelectronics Collaborate to Scale LoRa Technology to Meet High-Volume Demands of Internet of Things Applications

Cofely Services, a subsidiary of ENGIE (SUEZ group), integrates SIGFOX solution to expand services it provides for buildings

Paris Is 8th Largest City to Deploy Internet of Things from SIGFOX

LoRa® IoT Ecosystem

From www.st.com - December 14, 2015 7:27 AM

ST to offer complete line of solutions including LoRa systems on chips (SOCs) to accelerate deployments of low-power wide-area networks by mobile network operators (MNOs)

Sogedo et Sigfox lancent les compteurs d'eau intelligents



From www.sudouest.fr - December 16, 2015 2:24 PM

"Gestionnaire de réseaux dans les Landes, en Gironde et en Dordogne, Sogedo utilise les ondes radio de Sigfox pour relever les compteurs et surveiller l'état des canalisations. Le compteur..."

Mobile world Congress in Enevo

From www.enevo.com - March 6, 4:12 PM

T-Mobile to cover Czech Republic with the Internet of Things



From www.theinternetofthings.com - September 10, 4:41 PM

Following a pilot operation in the Czech Republic that exceeded expectations, T-Mobile SimpleCell Networks will deploy SIGFOX's Internet of Things network throughout the country.



"French Telecom Orange has chosen LoRa radio technology for its own domestic IoT and M2M network."

Orange has chosen to rely on LoRa (Long Range) technology to deploy this network that will cover the whole of metropolitan France.

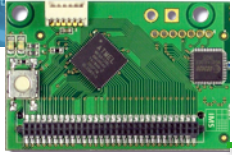

SOME SIGFOX RADIO MODULES

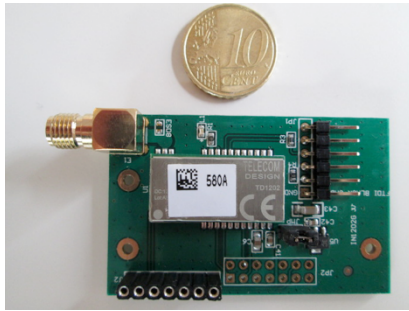

TD120x serie from Telecom Design



SigFox module from CookingHack (Libelium)



Adeunis SI868

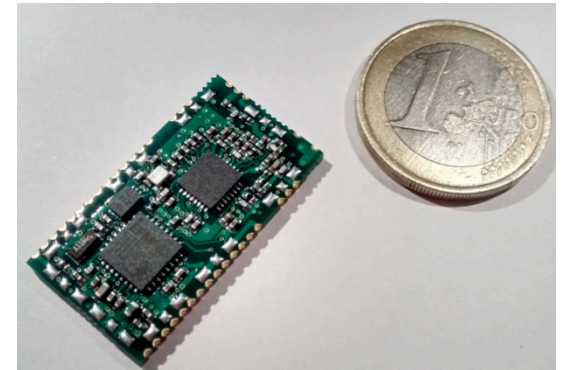

SIGT002 from CG-Wireless

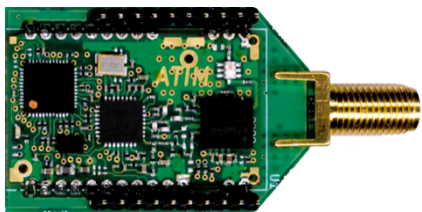

SigBee module from ATIM

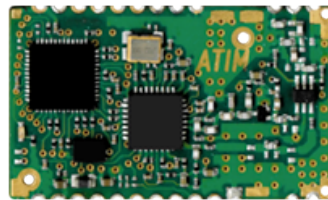

ARM-Nano N8 SigFox module from ATIM

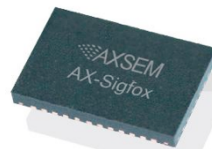

AXSEM SigFox module

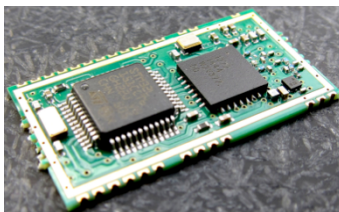
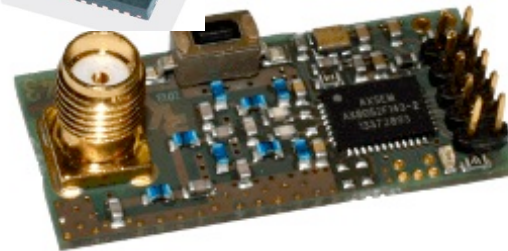

Nemeus MM002-LS-EU LoRa/SigFox



RC1682-SIG from RadioCraft



SigFox module from Snoc

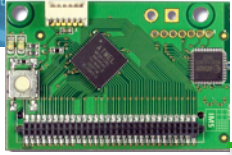

SOME READY-TO-USE SIGFOX DEVICES

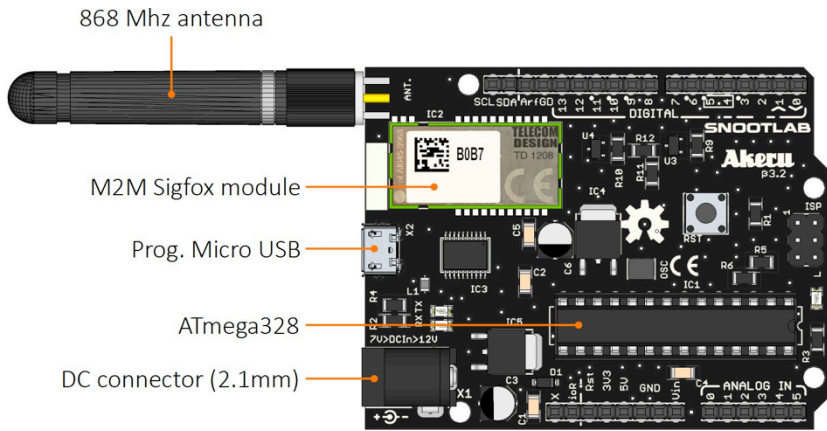

Snootlab Akeru is Arduino-like



SigFox demonstrator by Adeunis



Universal push button from Bttn Inc



SigFox ready sensor by ATIM



Sens'it from Axible Technologies



HidNSeek

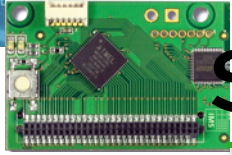

LoRa MODULES FROM SEMTECH'S SX127X CHIPS

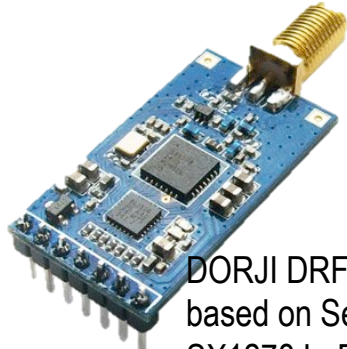

DORJI DRF1278DM is based on Semtech SX1278 LoRa 433MHz



Libelium LoRa is based on Semtech SX1272 LoRa 863-870 MHz for Europe



inAir9 based on SX1276



Froggy Factory LoRa module (Arduino)

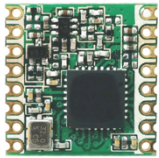

HopeRF RFM series



HopeRF HM-TRLR-D



LinkLabs Symphony module



IMST IM880A-L is based on Semtech SX1272 LoRa 863-870 MHz for Europe

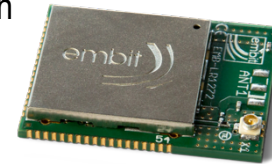

Embit LoRa

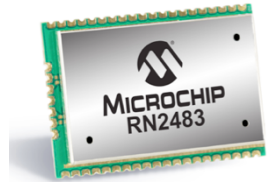

LoRa™ Long-Range Sub-GHz Module (Part # RN2483)

Microship RN2483



habSupplies



Adeunis ARF8030AA- Lo868

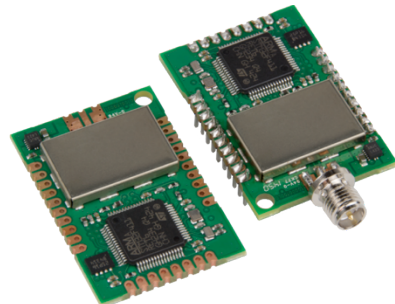

Multi-Tech MultiConnect mDot



AMIHO AM093



ARM-Nano N8 LoRa module from ATIM



SODAQ LoRaBee Embit

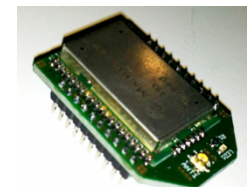

SODAQ LoRaBee RN2483



LORA MODULES FROM SEMTECH'S SX127X CHIPS



Libelium LoRa is based on Semtech SX1272 LoRa 863-870 MHz for Europe

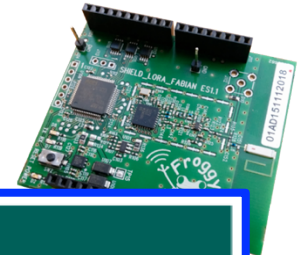

LoRa® Transceivers

Part Number	Frequency Range (MHz)	Link Budget (dB)	Rx Current (mA)	FSK max DR (kbps)	LoRa DR (kbps)	Max Sensitivity (dBm)	Tx Power (dBm)
SX1272	860 - 1020	158	10	300	0.3 - 37.5	-137	+ 20
SX1273	860 - 1020	150	10	300	1.7 - 37.5	-130	+ 20
SX1276	137 - 1020	168	9.9	300	0.018 - 37.5	-148	+ 20
SX1277	137 - 1020	158	9.9	300	1.7 - 37.5	-139	+ 20
SX1278	137 - 525	168	9.9	300	0.018 - 37.5	-148	+ 20

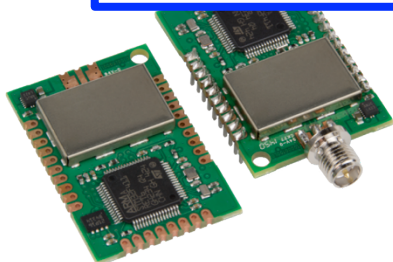

Multi-Tech MultiConnect mDot



habSupplies



AMIHO AM093

Adeunis ARF8030AA- Lo868

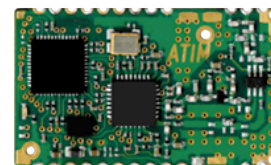

ARM-Nano N8 LoRa module from ATIM

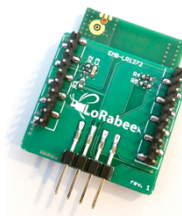

SODAQ LoRaBee Embit



SODAQ LoRaBee RN2483

Microship RN2483

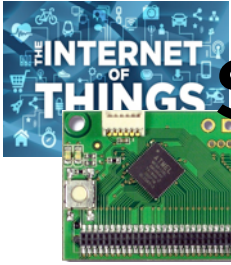

SOME READY-TO-USE LORA DEVICES



LoRa Mote from Semtech

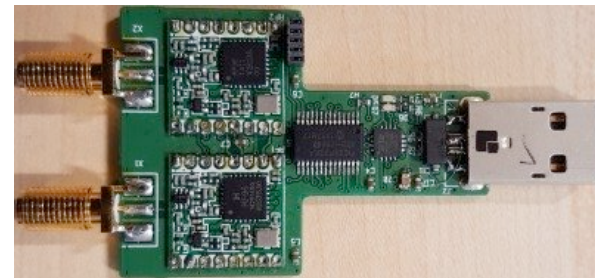
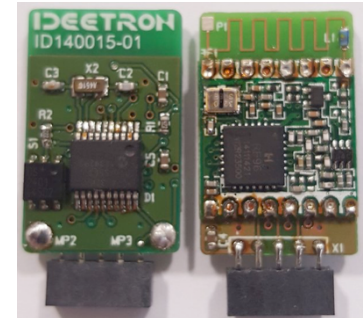
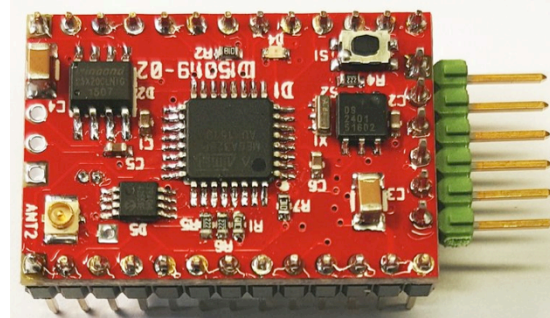

HopeRF/Ideetron notes



LoRa Alliance

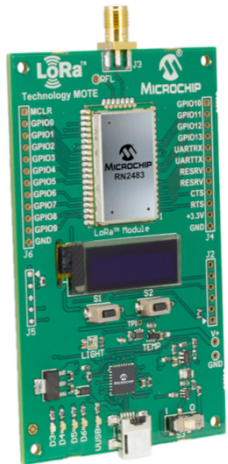

Microchip LoRa mote

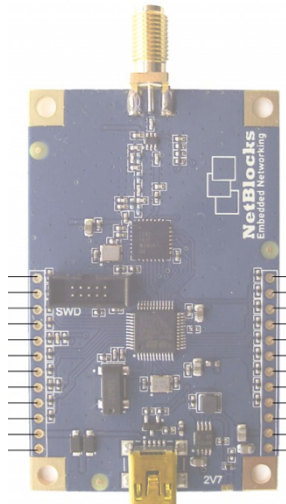

NetBlocks XRange

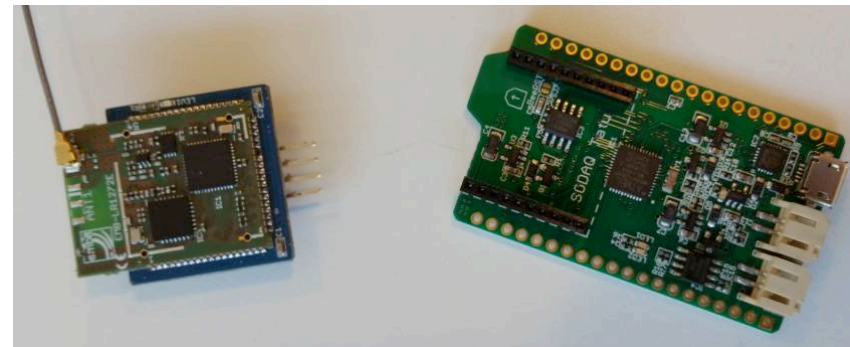

SODAQ Tatu with LoraBee (Embit) 32



SIGFOX'S MODEL FOR M2M: THE « OPERATOR » (ALL-IN-ONE) APPROACH

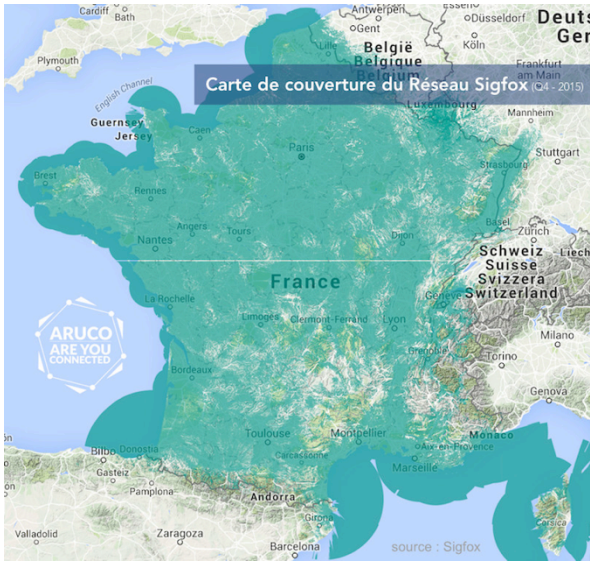

Figures from SigFox

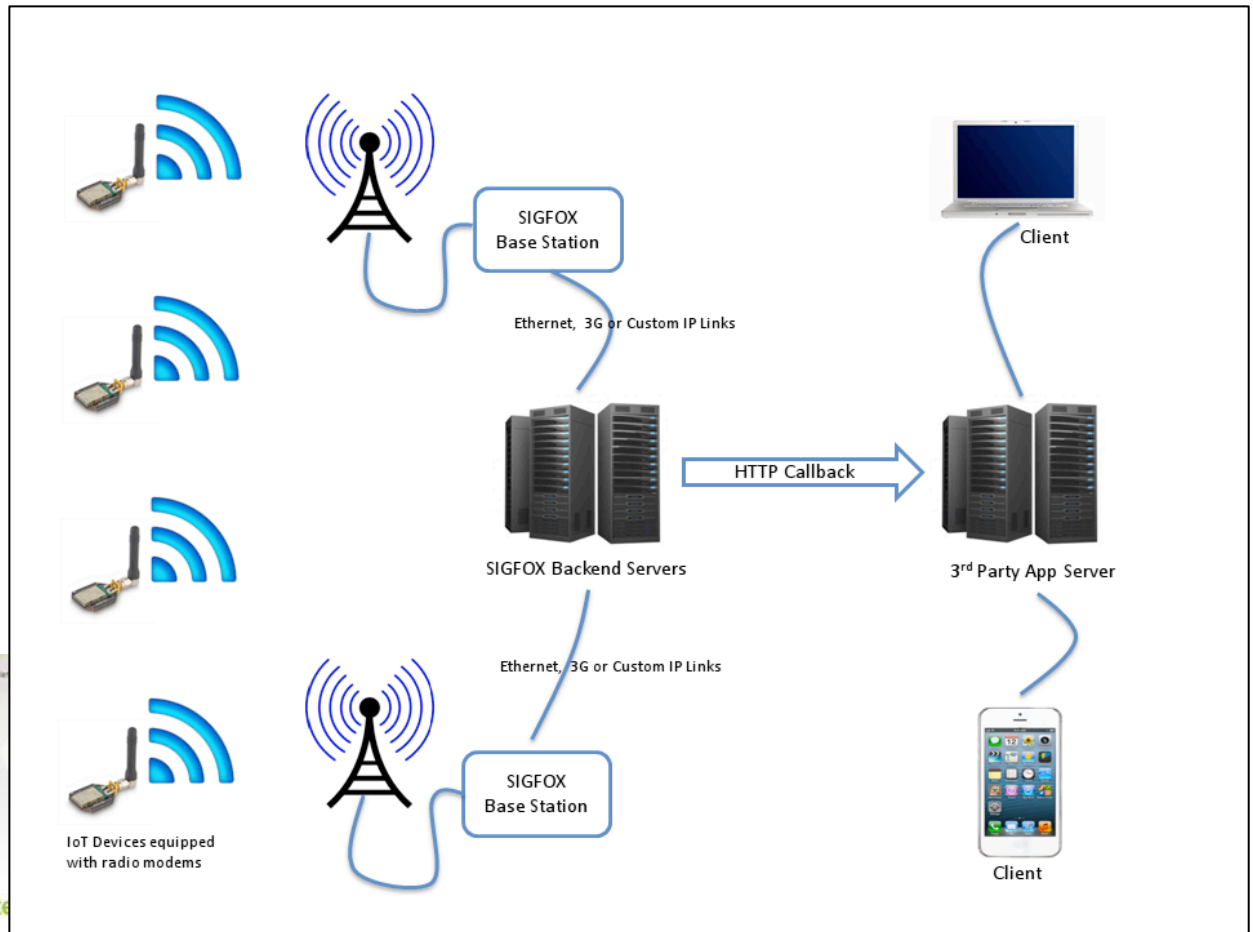

<http://www.scoop.it/t/toulouse-networks/?tag=SigFox>

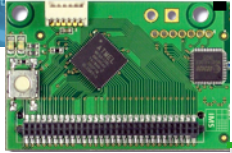

...vs PRIVATE LONG RANGE NETWORKS WITH LoRA

Add LoRa radio module to your preferred dev platform

Install a LoRa gateway and start collecting data

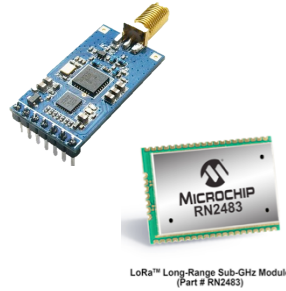

LoRa™ Long-Range Sub-GHz Module (Part # RN2483)

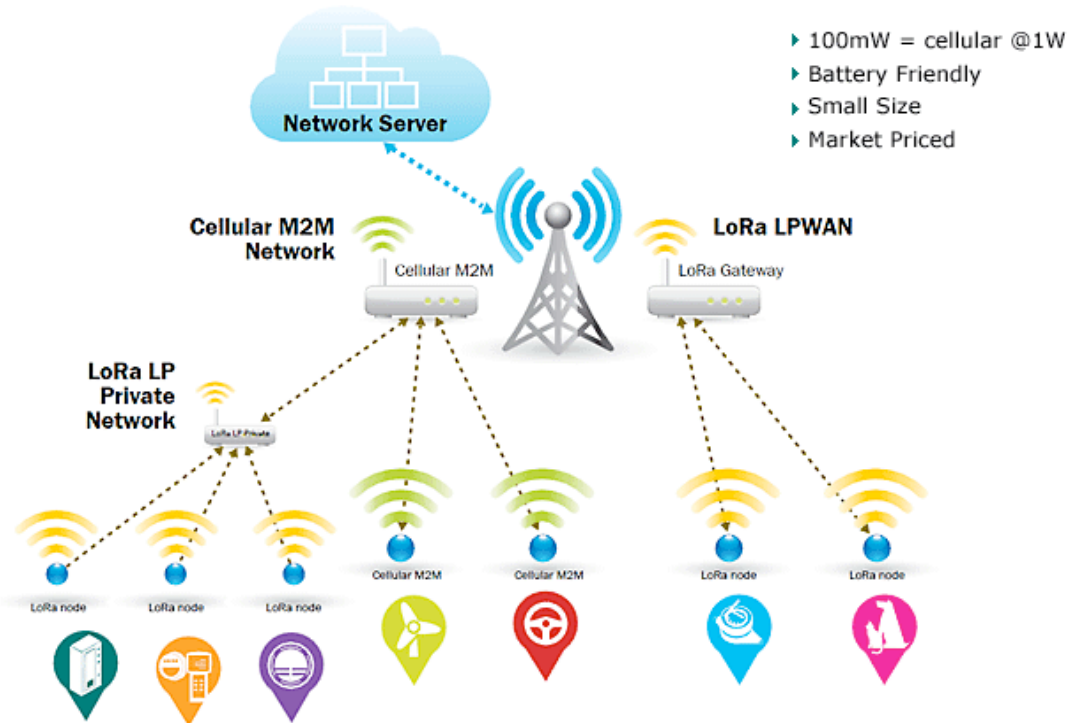
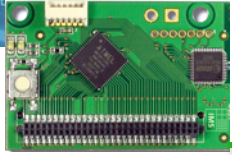

Figure from Semtech





LORA GATEWAYS (NON EXHAUSTIVE LIST)



Multi-Tech Conduit



Embedded Planet
EP-M2M-LORA



Ideeatron Lorank 8

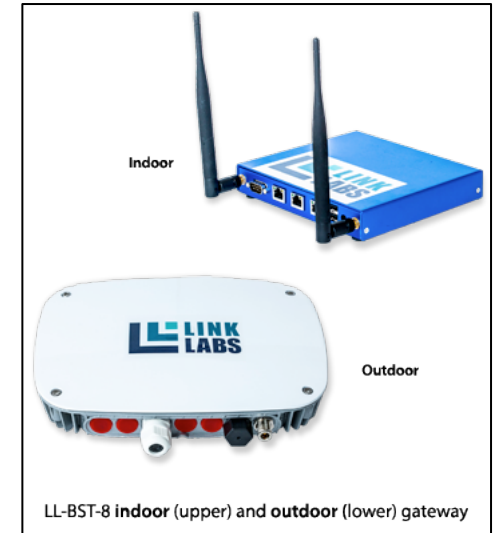

LinkLabs Symphony



PicoWAN from
Archos



TheThingNetwork



Kerlink IoT Station

Or build your own one:
Arduino, Raspberry Pi, ...



GATEWAYS/BS = CLOUD

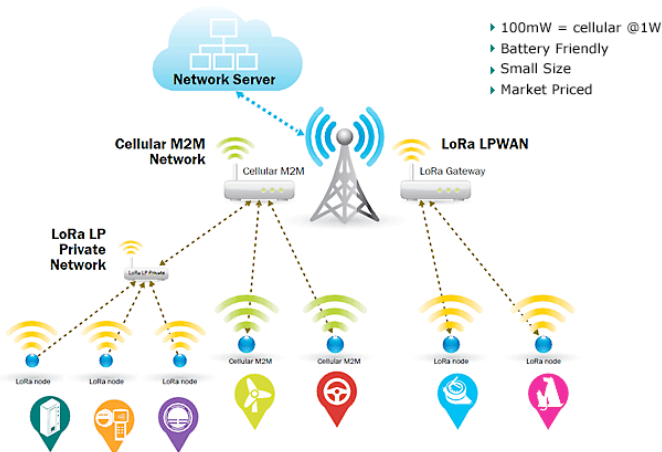
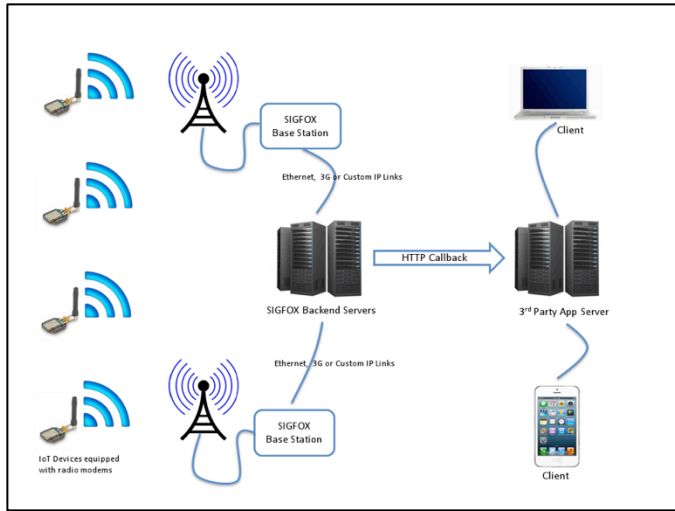

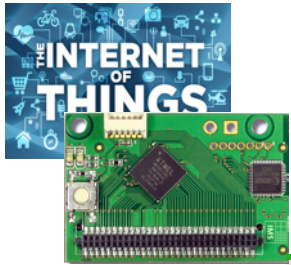

OTHER LONG-RANGE TECHNOLOGIES

	LoRa	NWave	OnRamp	Platanus	SIGFOX	Telensa	Weightless -N	Weightless -P	Amber Wireless	M2M Spectrum
Range (km) (Caveat)	15-45 flat; 15-22 suburban; 3-8 urban	10	4 (but claims 25x competition)	Several hundred meters	50 rural; 10 urban	Up to 8	5+	2+ urban	Up to 20	
Band (MHz)	Spread; varies by region	Sub-GHz	2.4 GHz	Sub-GHz	868; 902	868/915 470 (China)	Sub-GHz	Sub-GHz	434, 868, 2.4 GHz	800/900
ISM?	Yes	Yes	Yes	Yes	Yes	Yes	Yes	Yes	Yes	No
Symmetric up/down?	No	No	No (4:1)	No	No	Yes	Uplink only	Not yet determined		
Data rate (Caveat)	0.3-50 kbps (adaptive)	10							Up to 500 kbps**	
Max nodes	Depends; 200K-300K/hub	M							255 networks of 255 nodes	
OTA upgrades?	Yes	Yes								
Handoff?	No; no node/hub association	No; it's being considered	Yes	Yes	Doubtful	Yes	Yes	Yes		
Operational model	Public or private (expect 80% public)	Public or private	Public or private	Public or private	Public	Public	Public or private	Public or private		Public
Standard status (if any)	No	Weightless-N	IEEE; in process	Weightless-P	No	No (perhaps in future)	Yes	In process; spec later this yr		

WAVIoT: Nb-Fi with -154dBm (50km LOS, 10-15km urban)

Source: Bryon Moyer, "Low Power, Wide Area A Survey of Longer-Range IoT Wireless Protocols," *Electronic Engineering Journal*, Sept. 2015.

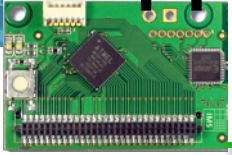
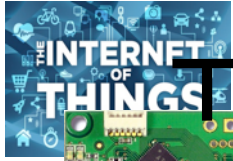

THE ISM/SRD LICENSE-FREE FREQUENCY BANDS

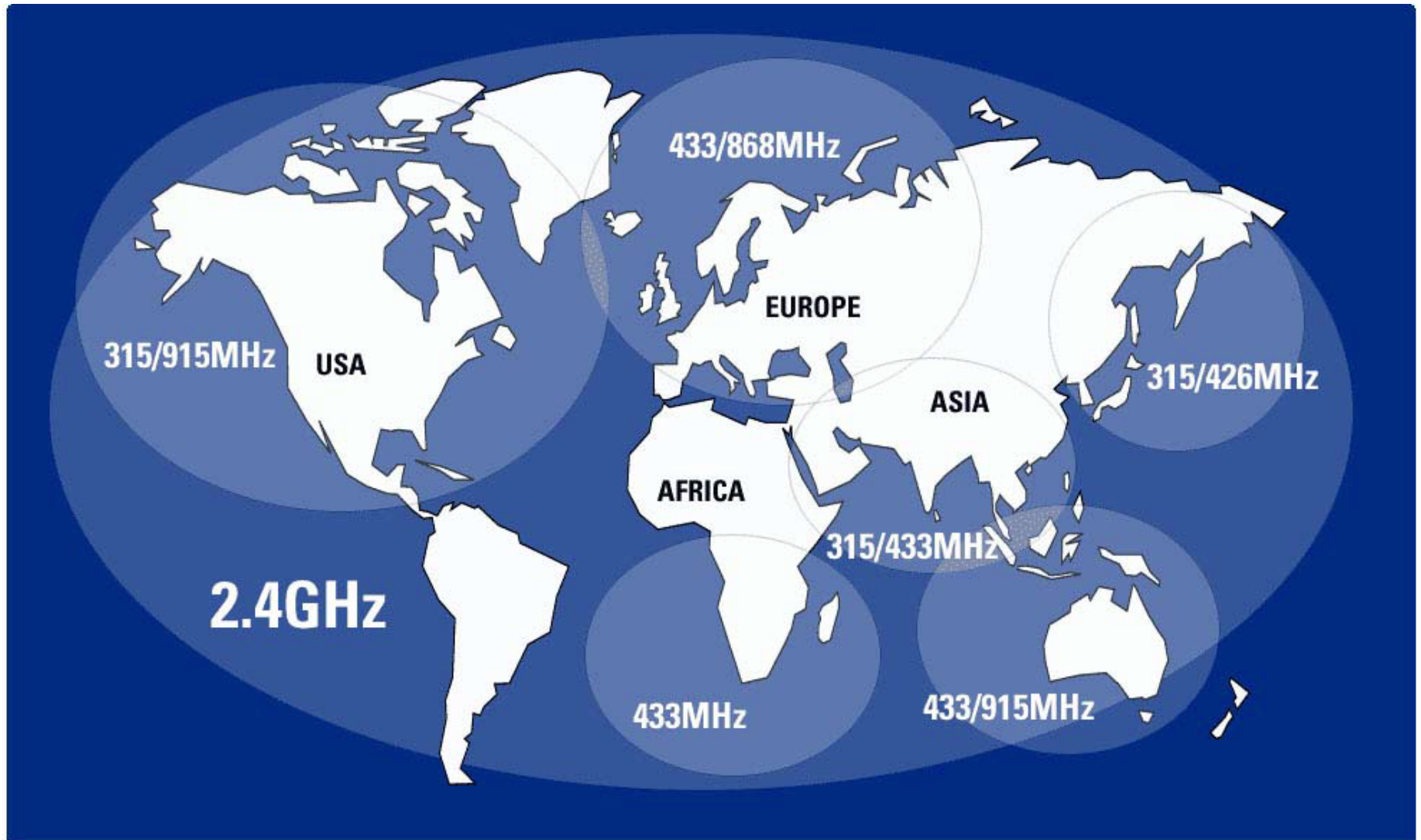

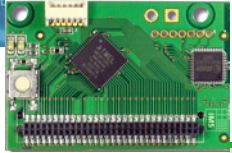

LICENSE-FREE SUB-GHZ CONSTRAINTS

- ❑ Shared medium so long-range transmission in dense environments can create lots of interference!
- ❑ Activity time is constrained from 0.1%, 1% 10% duty-cycle depending on frequency: 3.6s, 36s/hour to 360s/hour

Band	Edge Frequencies		Field / Power	Spectrum Access	Band Width
	Fe-	Fe+			
g(Note 7)	865 MHz	868 MHz	+6.2 dBm /100 kHz	1 % or LBT AFA	3 MHz
g(Note 7)	865 MHz	870 MHz	-0.8 dBm / 100 kHz	0.1% or LBT AFA	5 MHz
g1	868 MHz	868.6	14 dBm	1 % or LBT AFA	600 kHz
g2	868.7 MHz	869.2 MHz	14 dBm	0.1% or LBT AFA	500 kHz
g3	869.4 MHz	869.65 MHz	27 dBm	10 % or LBT AFA	250 kHz
g4	869.7 MHz	870 MHz	7 dBm	No requirement	300 kHz
g4	869.7 MHz	870 MHz	14 dBm	1 % or LBT AFA	300 kHz

For SigFox, the operator typically limits the number of messages per day (140) with penalty for over usage. e.g. new messages/day = $140 - (2 * \llcorner \#msg_overuse \llcorner)$ applied during $\llcorner \#msg_overuse \llcorner$ days

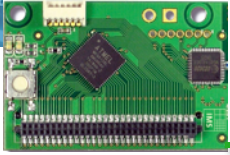

LBT+AFA

- ❑ Listen Before Talk and Adaptive Frequency Agility can relax the duty-cycle constraints...
- ❑ ... but still
 - ❑ 100s / hour on every 200kHz BW
 - ❑ **no more than 1s for a single transmission** 😞😞
- ❑ ... so may not be that interesting!

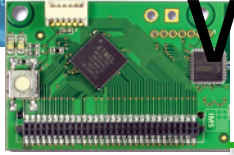

WHAT ABOUT RELIABILITY?

- ❑ Using the g3 band, 10% duty cycle can be achieved for the gateway on the downlink
- ❑ However, handling ACKs for a large number of devices is not possible
- ❑ SigFox uses repetition

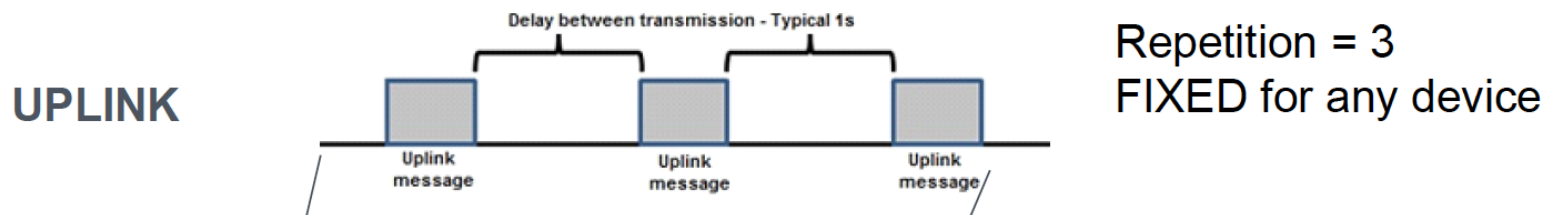

- ❑ LoRa uses coding gain (with the coding rate) and spread spectrum higher immunity to interferences
- ❑ ACKs may be reserved for critical transactions

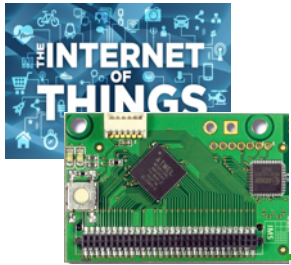

LoRa™ Alliance

Wide Area Networks for IoT

Sponsor members



Contributor members



Adopter members





WHAT IS LORAWAN?

Class A: Receiver Initiated Transmission strategy (RIT)

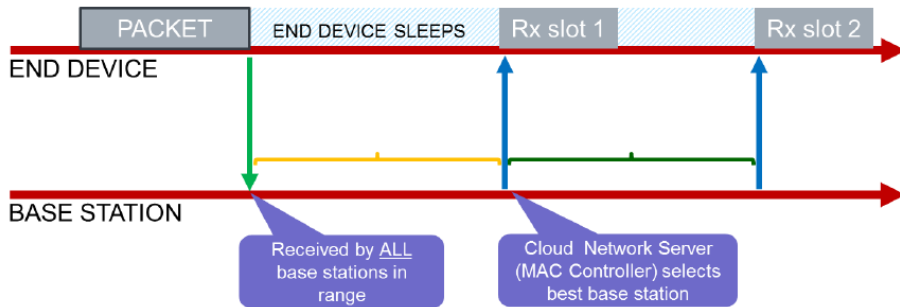

Class B: Coordinated Sampled Listening (CSL)

Network may send downlink packet to node at any Rx slot

END DEVICE

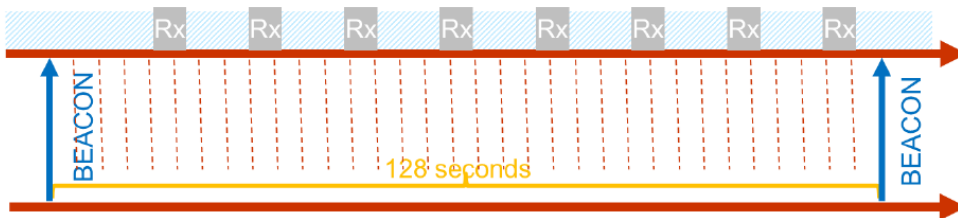

BASE STATION

Class C: Continuous Listening

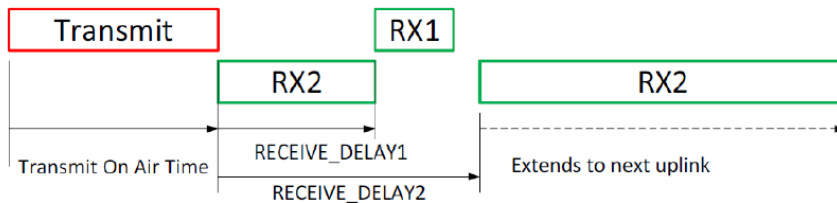

Application				
LoRa [®] MAC				
MAC options				
Class A (Baseline)	Class B (Baseline)	Class C (Continuous)		
LoRa [®] Modulation				
Regional ISM band				
EU 868	EU 433	US 915	AS 430	—

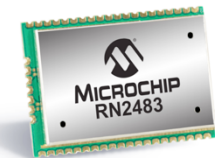
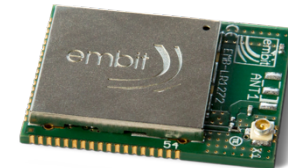

LoRa™ Long-Range Sub-GHz Module (Part # RN2483)

Power Efficiency ↑ Latency constrained applications ↓

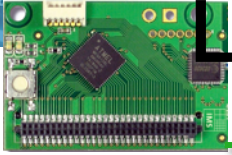

LORAWAN ARCHITECTURE

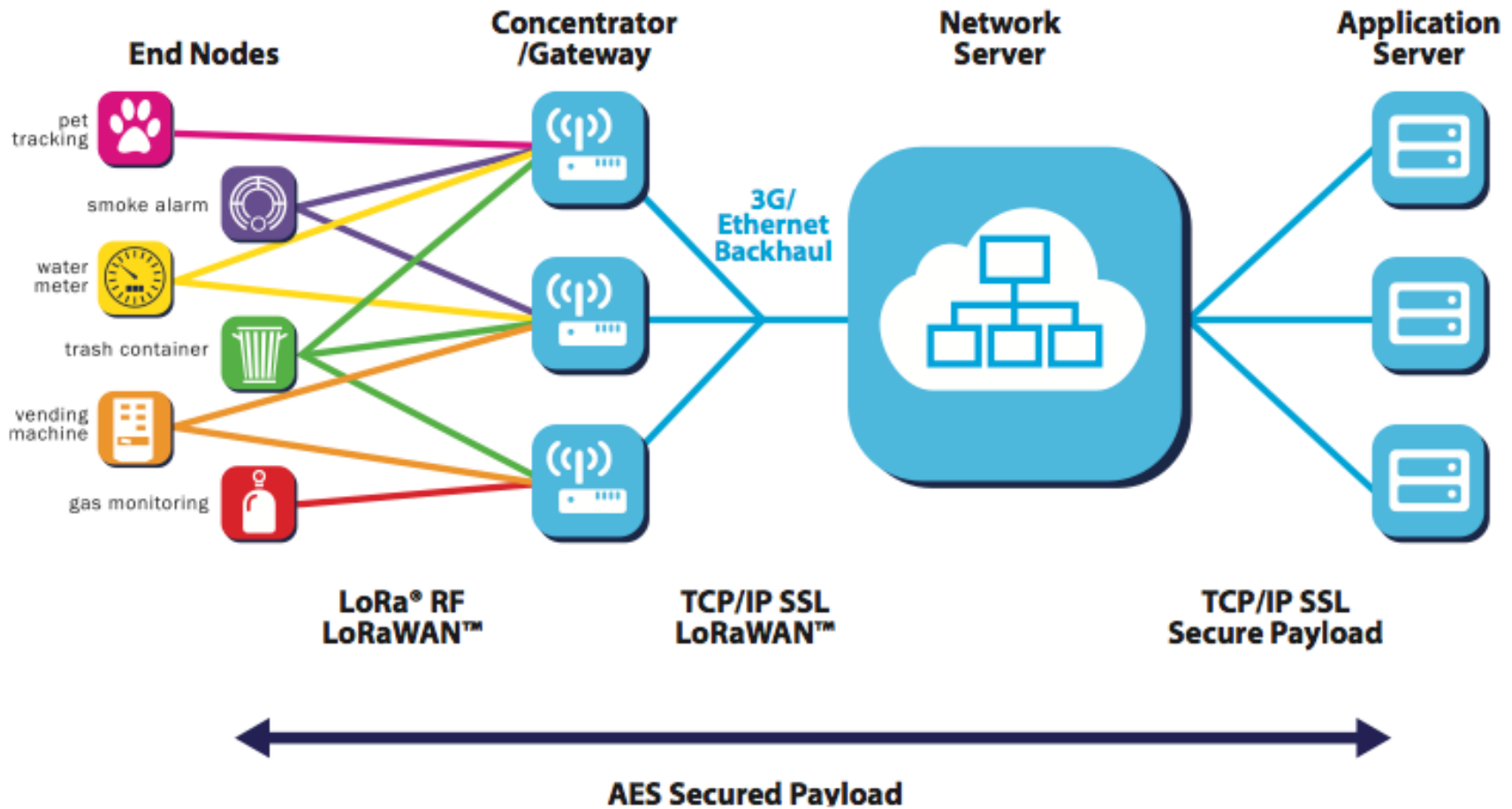

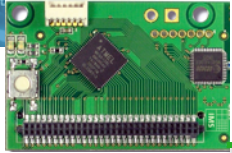

LORAWAN CHANNELS

□ EU 863-870MHz ISM Band

DataRate	Configuration	Indicative physical bit rate [bit/s]	TXPower	Configuration
0	LoRa: SF12 / 125 kHz	250	0	20 dBm (if supported)
1	LoRa: SF11 / 125 kHz	440	1	14 dBm
2	LoRa: SF10 / 125 kHz	980	2	11 dBm
3	LoRa: SF9 / 125 kHz	1760	3	8 dBm
4	LoRa: SF8 / 125 kHz	3125	4	5 dBm
5	LoRa: SF7 / 125 kHz	5470	5	2 dBm
6	LoRa: SF7 / 250 kHz	11000	6..15	RFU
7	FSK: 50 kbps	50000		
8..15	RFU			

Table 14: Data rate and TX power table

□ Minimum set

Modulation	Bandwidth [kHz]	Channel Frequency [MHz]	FSK Bitrate or LoRa DR / Bitrate	Nb Channels	Duty cycle
LoRa	125	868.10 868.30 868.50	DR0 to DR5 / 0.3-5 kbps	3	<1%

Table 12: EU863-870 default channels

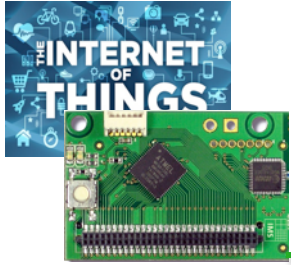

WILL MAIN MARKET BE OPERATOR BASED?



Long Range

- Greater than cellular
- Deep indoor coverage
- Star topology

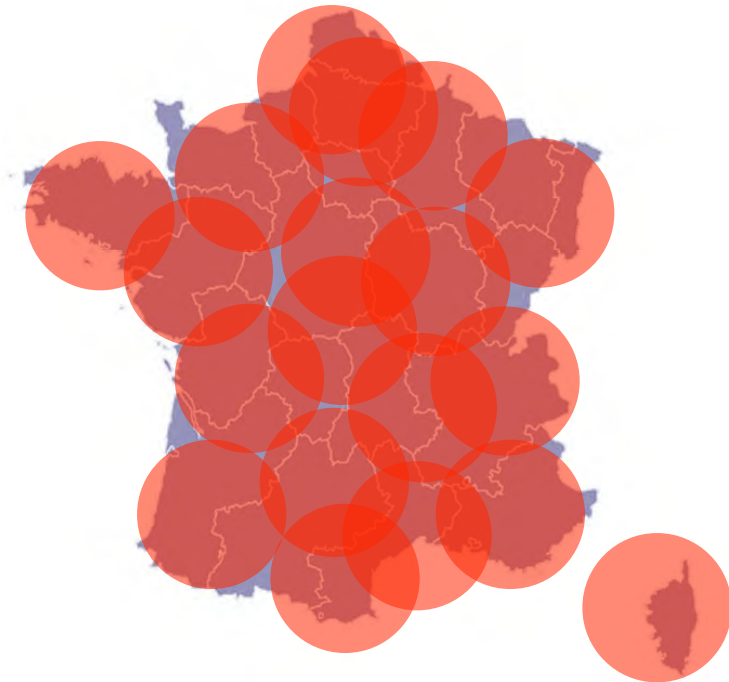

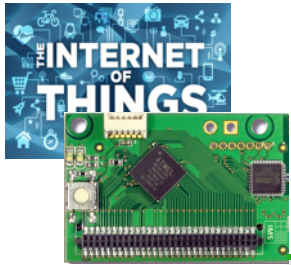

...COMMUNITY BASED?



Communities



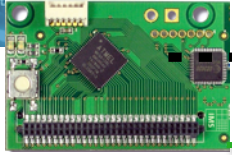

OR FROM LOCAL ACTORS?



Irrigation



Livestock farming



Fish farming & aquaculture



Storage & logistic



Agriculture



Fresh water

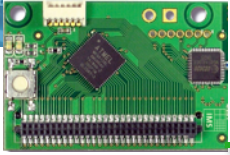

WHAT ABOUT QUALITY OF SERVICE?

Regulations stipulate that **radio activity duty-cycle should be enforced at devices** and that end-users should not be able to modify it « easily ».

LoRaWAN specification from LoRa Alliance is a first attempt to standardize LoRa networks but **no issues on quality of service**.

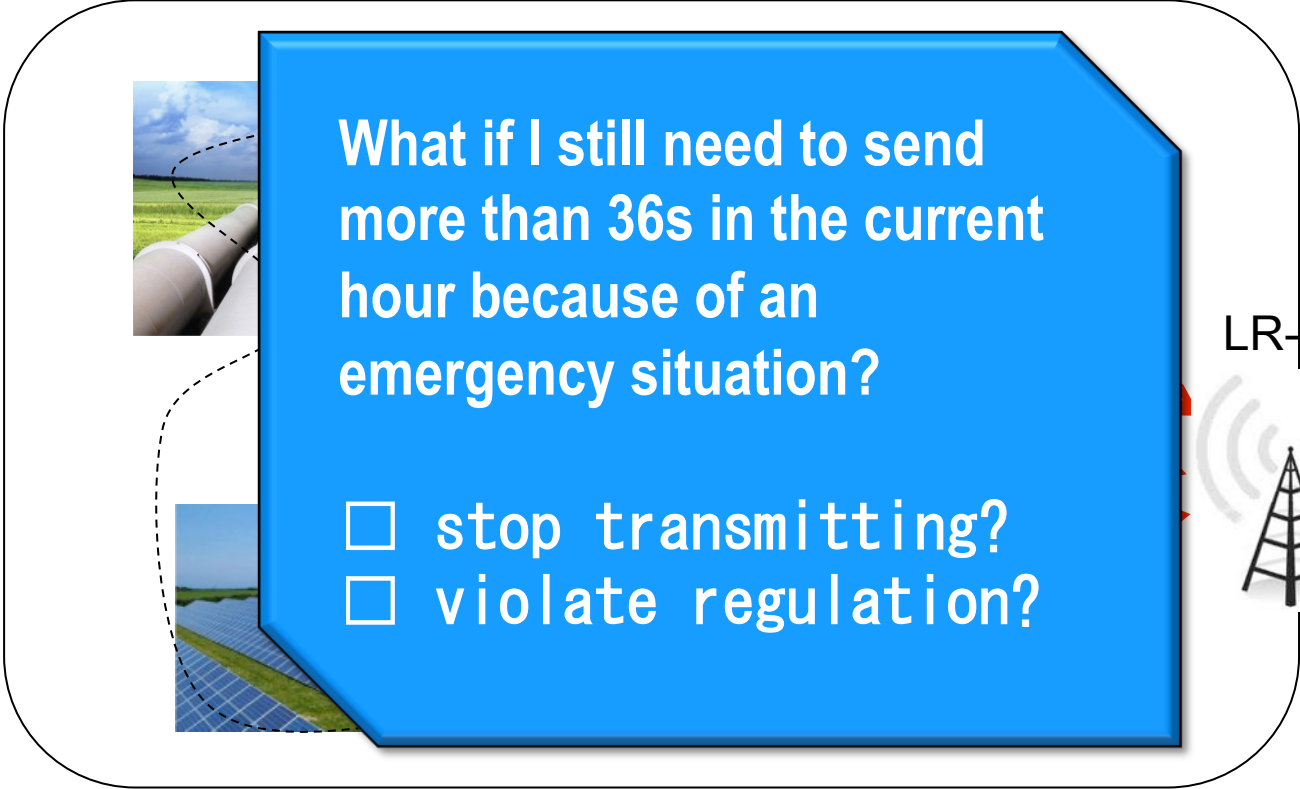

What if I still need to send more than 36s in the current hour because of an emergency situation?

- stop transmitting?
- violate regulation?

LR-BS



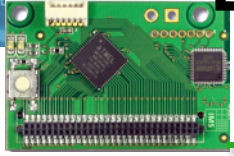

LONG-RANGE VERSION OF OUR IMAGE SENSOR

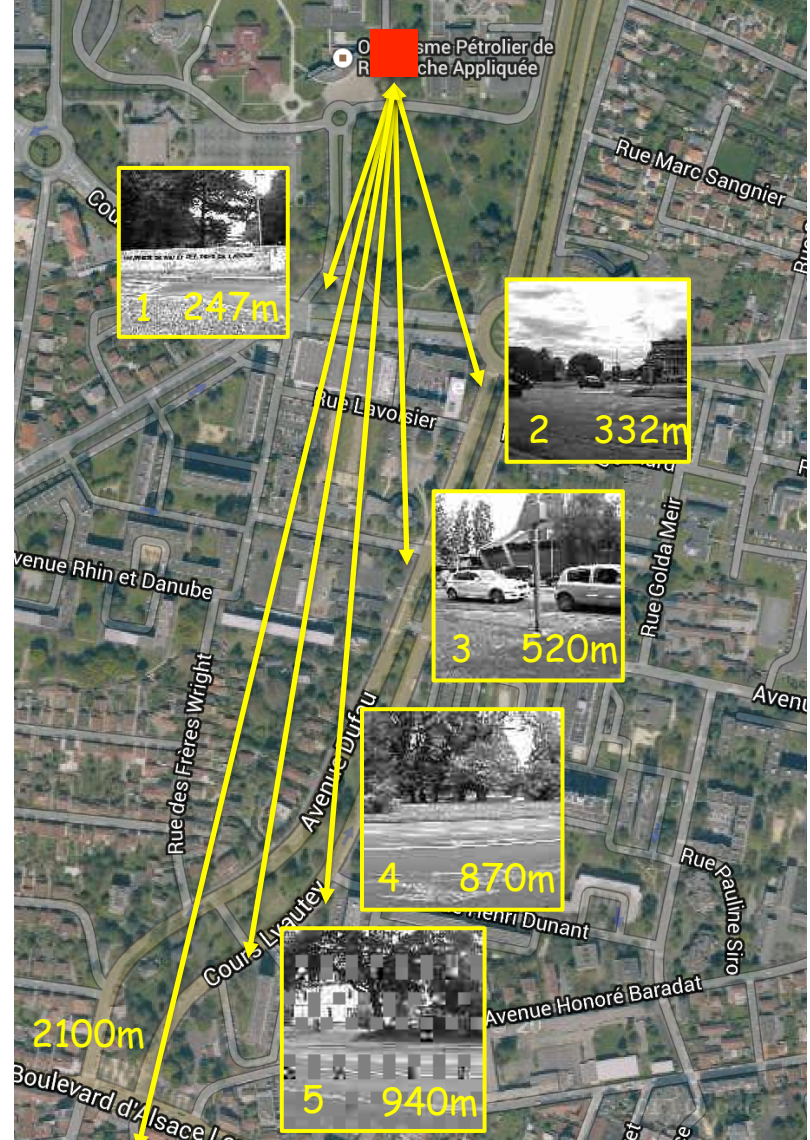
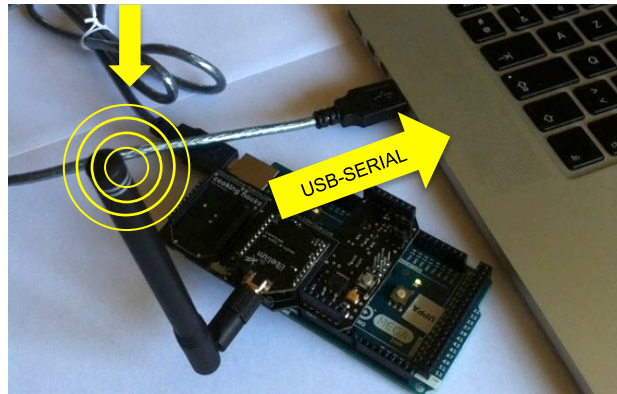
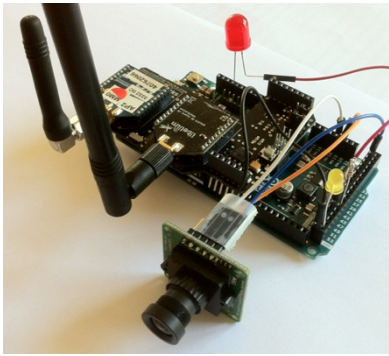

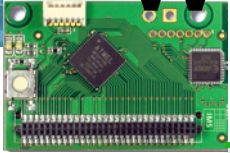

WHAT IF I WANT TO TRANSMIT IMAGES?

LoRa mode	BW	CR	SF	time on air in second for payload size of					
				5 bytes	55 bytes	105 bytes	155 Bytes	205 Bytes	255 Bytes
1	125	4/5	12	0.95846	2.59686	4.23526	5.87366	7.51206	9.15046
2	250	4/5	12	0.47923	1.21651	1.87187	2.52723	3.26451	3.91987
3	125	4/5	10	0.28058	0.69018	1.09978	1.50938	1.91898	2.32858
4	500	4/5	12	0.23962	0.60826	0.93594	1.26362	1.63226	1.95994
5	250	4/5	10	0.14029	0.34509	0.54989	0.75469	0.95949	1.16429
6	500	4/5	11	0.11981	0.30413	0.50893	0.69325	0.87757	1.06189
7	250	4/5	9	0.07014	0.18278	0.29542	0.40806	0.5207	0.63334
8	500	4/5	9	0.03507	0.09139	0.14771	0.20403	0.26035	0.31667
9	500	4/5	8	0.01754	0.05082	0.08154	0.11482	0.14554	0.17882
10	500	4/5	7	0.00877	0.02797	0.04589	0.06381	0.08301	0.10093



Optimized image encoding at medium quality: 16384b down to 1366b (ratio 12).

Will generate 7 pkts using 250 max payload



$$7 * 9.15 = 64.05s$$

$$7 * 1.96 = 13.72s$$

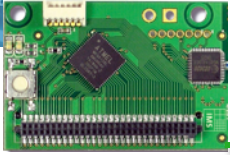

LONG-RANGE ACTIVITY SHARING (LAS)

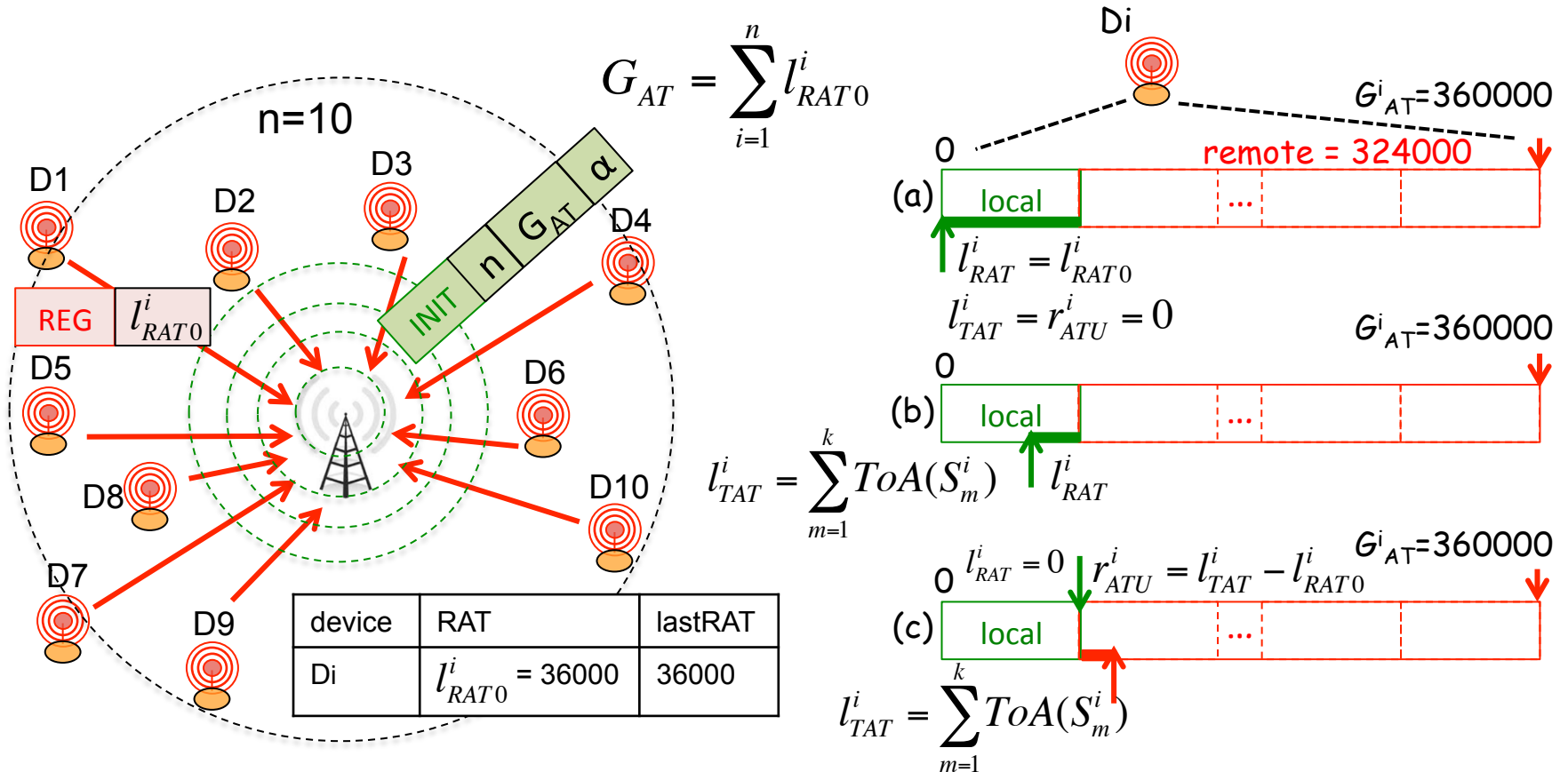

A device can transmit more if needed, provided that other devices will decrease their radio activity time accordingly.

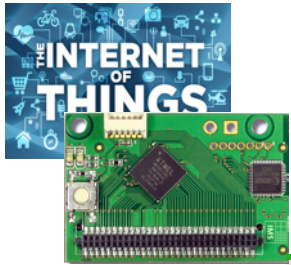

DISTRIBUTING REMOTE ACTIVITY TIME USAGE

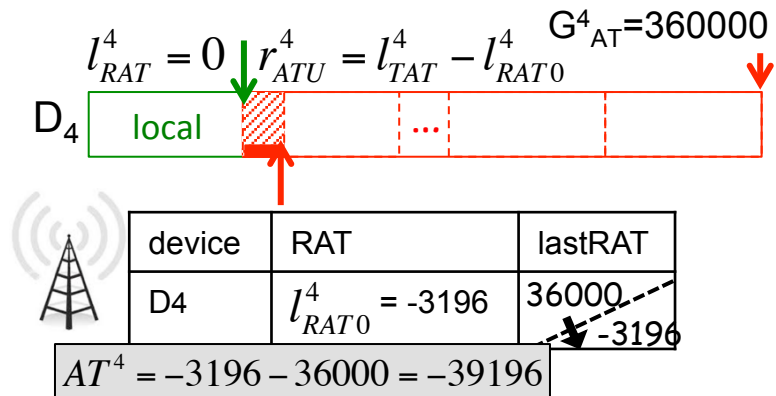
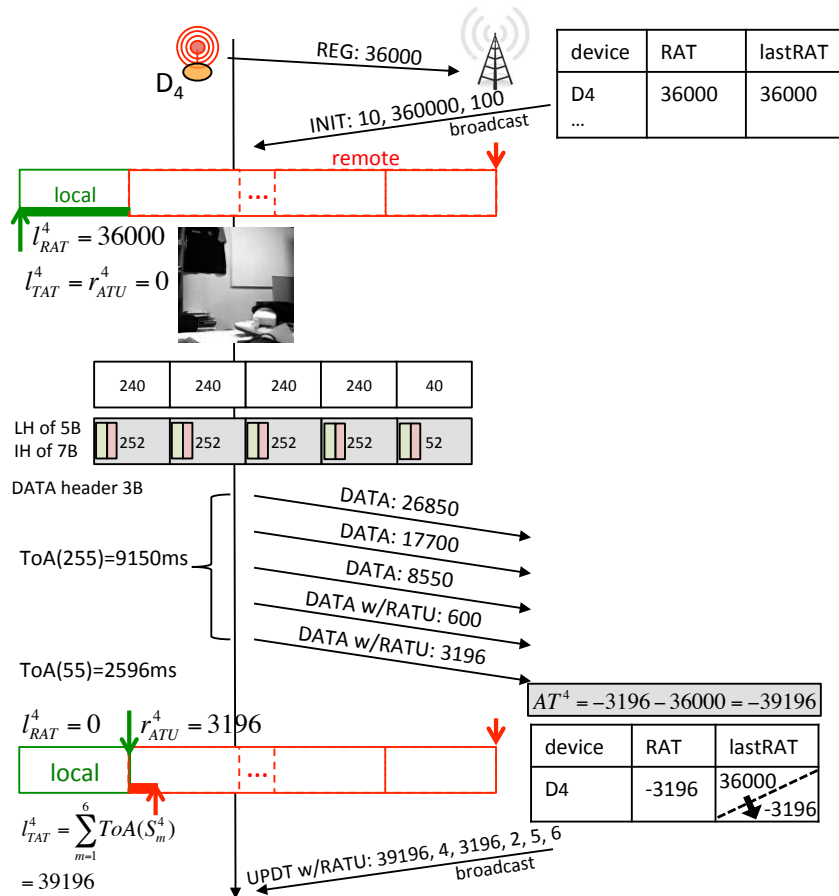

UPDT w/RATU	39196	4	$n_d=2$	3196	5	6
-------------	-------	---	---------	------	---	---

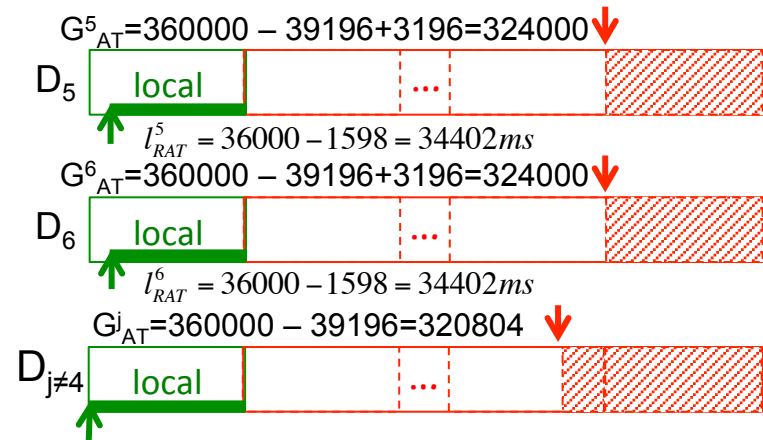

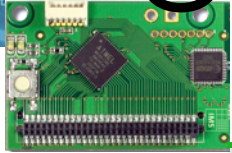

OTHER ISSUES TO TAKE INTO ACCOUNT

- ❑ Minimise the number of UPDT messages sent by the gateway because the gateway's radio time is also limited
 - ❑ UPDT can have cumulative behavior if no remote activity time has been used
- ❑ Support sleep periods of end-devices
 - ❑ The network is synchronized for control messages (REG, INIT, UPDT). UPDT msg that can not use cumulative behavior are queued for transmission at next transmission slot. At rcv, UPDT have to be applied sequentially.
- ❑ Maintain (loose) synchronization
 - ❑ If no UDPT are scheduled, the gateway periodically sends a BEACON. Clock drift is limited to a BEACON period
- ❑ Dynamic insertion of new end-devices
 - ❑ New devices can either stay out of the managed pool (then only 36s of activity time/h is allowed), or join by waiting for the next UPDT/BEACON msg
 - ❑ Every hour, end-devices decide if they want to join the pool or not
- ❑ Give priority to control msg
 - ❑ SIFS/DIFS mechanism are implemented using LoRa Channel Activity Detection
- ❑ Avoid interleaving of several image transmissions
 - ❑ Use DIFS for first image packet, then SIFS
- ❑ Improve LoRa network efficiency
 - ❑ Move from pure ALOHA to CSMA mechanism with CAD+RSSI tests prior to any transmission

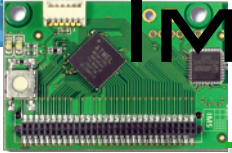
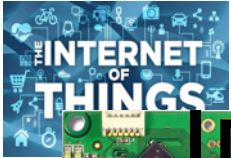

IMPLEMENTATION AVAILABLE



```
pi@raspberr... x pi@raspberr... x
pi@raspberrypi ~$ python ./parseLoRaStdin.py
Power ON: state ...
0
LoRa mode: state 0
Channel CH_10_868: state 0
Power M: state 0
Get Preamble Length: state 0
Preamble Length: 8
LoRa addr 1 : state 0
SX1272 configured as LR-BS. Waiting RF input for transparent RF-serial bridge
%LASBase::ON
%LAS::ON
%LASBase::clear dev table
----- Rcv from LoRa. src=10 seq=7 len=10 SNR=7 RSSIpkt=-62
rcv ctrl pkt info: 10,7,10,7,-62

splitted in: [10, 7, 10, 7, -62]
(src=10 seq=7 len=10 SNR=7 RSSI=-62)
%LASBase::rcv LAS message
%LASBase::LAS payload size is 10
%LASBase::DATA msg
%LASBase::process DATA msg from 10
%LASBase::advertised lrat is 33301
%LASBase::dev_table index 0
%LASBase::can find device
hello
```

```
Kcv serial: hello
Sending. Length is 5
hello
LASDevice::Payload size is 15
LASDevice::ToA is 322
LASDevice::alpha*gat is 36000
LASDevice::_lrat is 2699
LASDevice::_lrat is 33301
LASDevice::sending w/LP
LAS::CAD duration 138
LAS::CAD OK1
--> waiting for 6 CAD = 96
--> CAD duration 138
LAS::CAD OK2
LAS::check RSSI
--> RSSI -114
LASDevice::LoRa Sent in 541
LASDevice::LoRa Sent w/CAD in 916
Packet sent, state 0
```



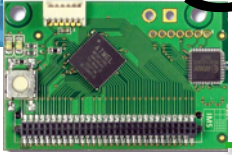

SENDING MESSAGE UNDER LAS SERVICES

```
pi@raspberr... x pi@raspberr... x
----- Rcv from LoRa. src=10 seq=8 len=5 SNR=7 RSSIpkt=-55
rcv_ctrl_pkt_info: 10,8,5,7,-55

splitted in: [10, 8, 5, 7, -55]
%LASBase::rcv LAS message
%LASBase::LAS payload size is 5
%LASBase::REG msg
%LASBase::process REG msg from 10
%LASBase::advertised lrat0 is 36000
%LASBase::dev_table index 0
%LASBase::added in dev_table
%LASBase::_n_d is 1

----- Rcv from LoRa. src=10 seq=9 len=10 SNR=9 RSSIpkt=-53
rcv_ctrl_pkt_info: 10,9,10,9,-53

splitted in: [10, 9, 10, 9, -53]
(src=10 seq=9 len=10 SNR=9 RSSI=-53)
%LASBase::rcv LAS message
%LASBase::LAS payload size is 10
%LASBase::DATA msg
%LASBase::process DATA msg from 10
%LASBase::advertised lrat is 32979
%LASBase::dev_table index 0
%LASBase::data length is 10
%LASBase::computes ToA on 15B is 322
%LASBase::mismatched lrat, update
%LASBase::w/LP
%LASBase::send UPDT with 3021,10
%LASBase::Payload size is 11
%LASBase::ToA is 281
%LASBase::toa control disabled
%LAS::CAD duration 66
%LAS::CAD OK1
%LAS::check RSSI
--> RSSI -100
hello
```



```
Rcv serial: /@REG#
c Parsing command
pi Send LAS REG msg
LASDevice::REG with 36000
LASDevice::Payload size is 10
LASDevice::ToA is 281
o LASDevice::disabled
ec LAS::CAD duration 46
LAS::CAD OK1
LAS::check RSSI
--> RSSI -115
-c LASDevice::LoRa Sent in 499
LASDevice::LoRa Sent w/CAD in 546
```

```
hello
LASDevice::Payload size is 15
LASDevice::ToA is 322
LASDevice::alpha*gat is 36000
LASDevice::_ltat is 3021
LASDevice::_lrat is 32979
LASDevice::sending w/LP
o LAS::CAD duration 138
ec LAS::CAD OK1
pu --> waiting for 6 CAD = 96
LAS::CAD OK2
LAS::check RSSI
i --> RSSI -115
LASDevice::LoRa Sent in 541
LASDevice::LoRa Sent w/CAD in 915
LASDevice::Packet sent, state 0
LASDevice::Rcv from LoRa. src=1 seq=0 len=6 SNR=8
LASDevice::^1,0,6,8,-55
rcv LAS message
LASDevice::
LASDevice::UPDT msg
LASDevice::process UPDT msg 4426617
LASDevice::AT is 3021
LASDevice::Di is 10
LASDevice::nothing to be done
```

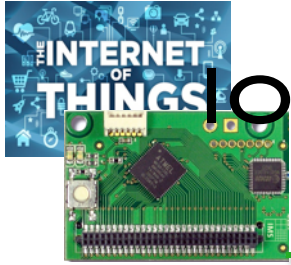

IoT FOR RURAL APPLICATIONS IN DEVELOPPING COUNTRIES

- ❑ WAZIUP is an EU H2020 project (2016-2019)
- ❑ contributes to long-range networks for rural applications with WP2

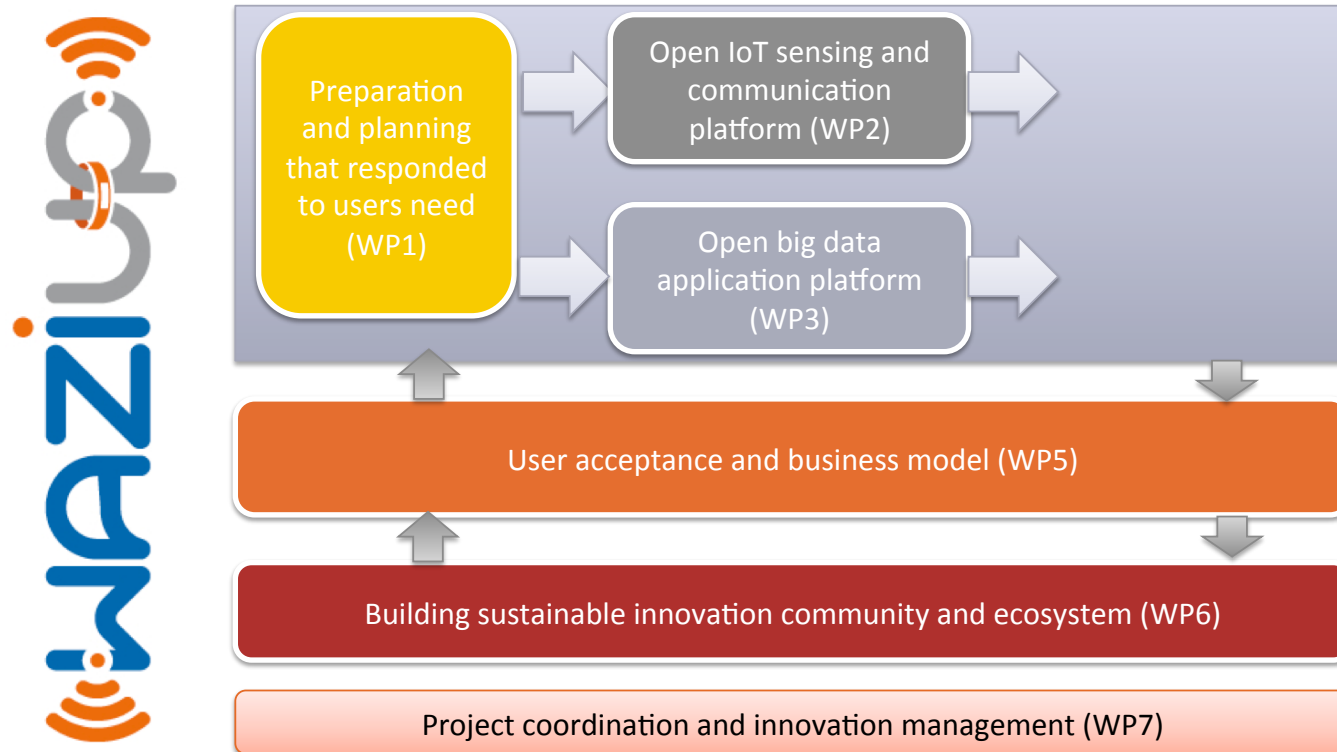



DESIGN AND ADAPTATION

- ❑ Build low-cost, low-power, Long-range enabled generic platform
- ❑ Methodology for low-cost platform design
- ❑ Technology transfers to user communities, economic actors, stakeholders,...

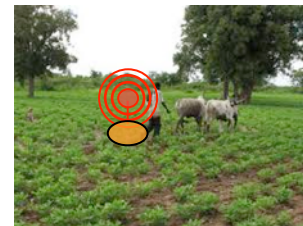
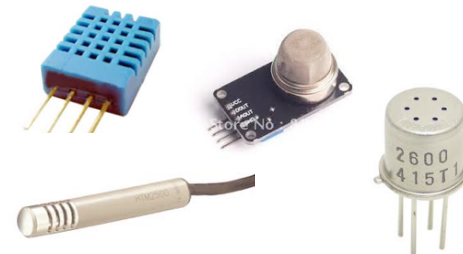
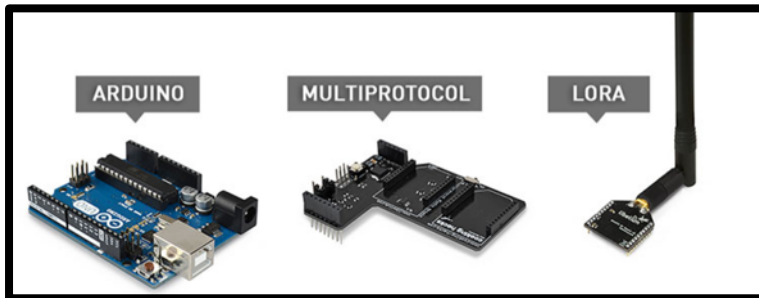



DESIGN AND ADAPTATION

- ❑ Build low-cost, low-power, Long-range enabled generic platform
- ❑ Methodology for low-cost platform design
- ❑ Technology transfers to user communities, economic actors, stakeholders,...

ARDUI

Pro Mini atmega328 3.3V 8M

For Arduino Compatible Nano

New Pro Mini atmega328 3.3 V 8 M remplacer ATmega128 pour

US \$1.86 / pièce

© Laurent Gerner, SaadLoul



LOW-COST LORA GATEWAY: LESS THAN 50€

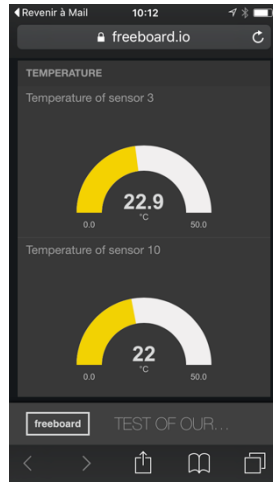
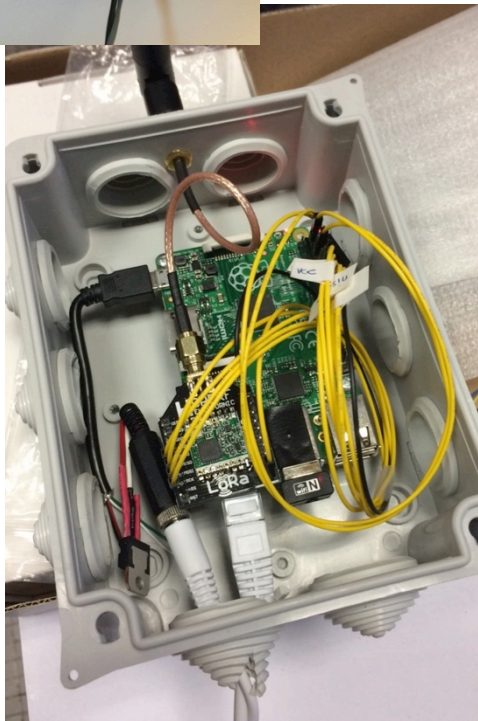

Dropbox

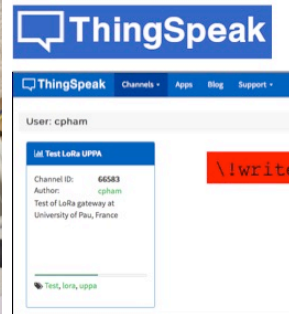

!:#19.6

Node 10

!write_key#field_index#19.6

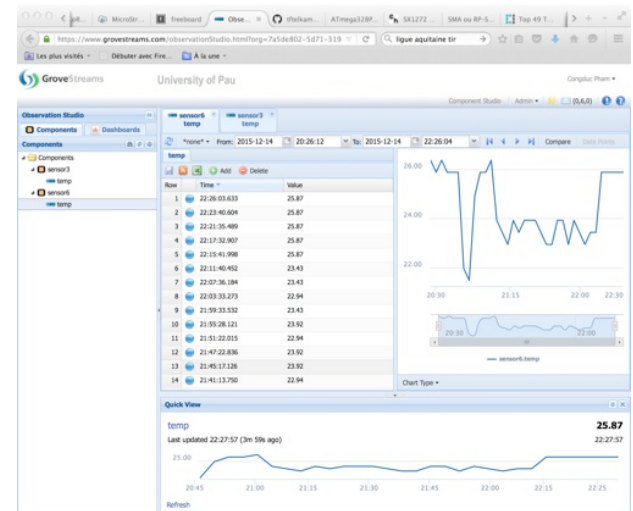
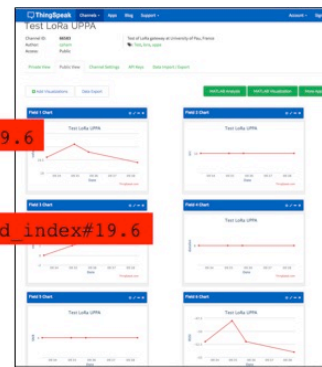



LOW-COST LORA GATEWAY: LESS THAN 50€

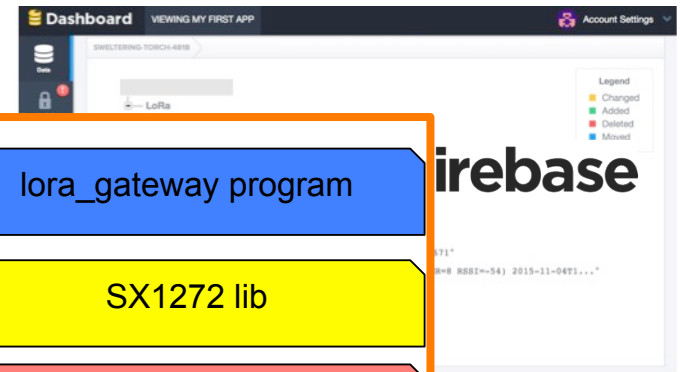
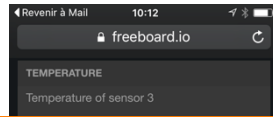
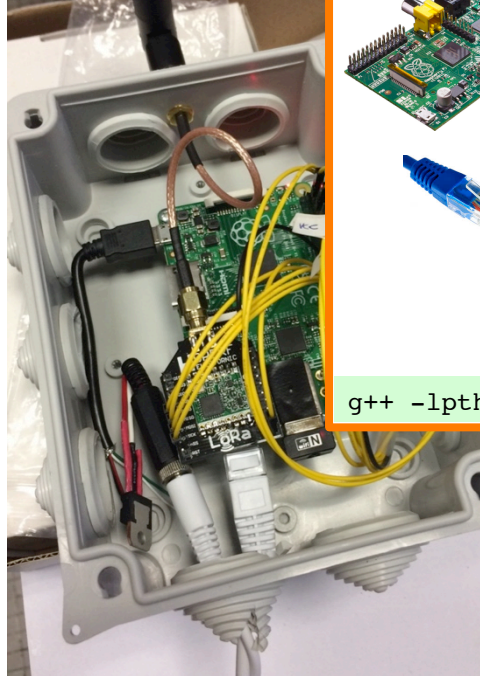

firebase

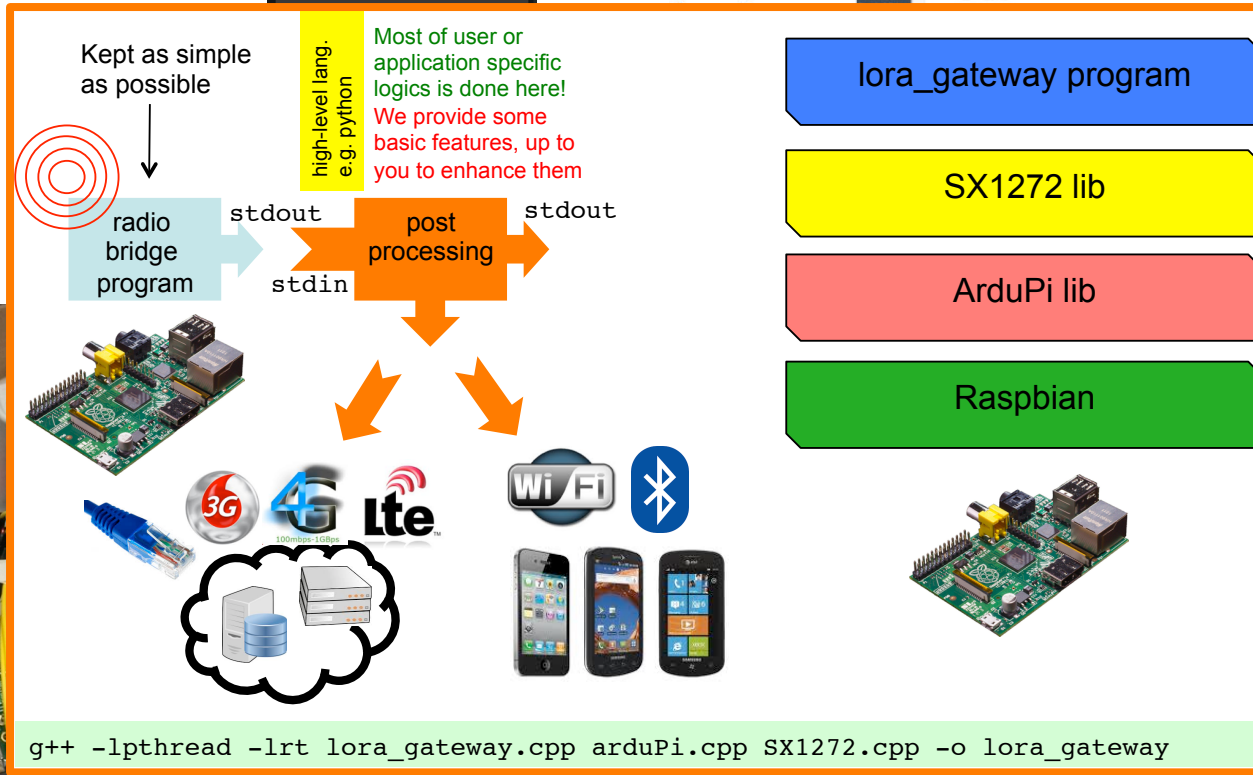

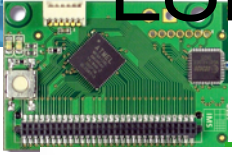

LONG-RANGE TEST-BED & BENCHMARK

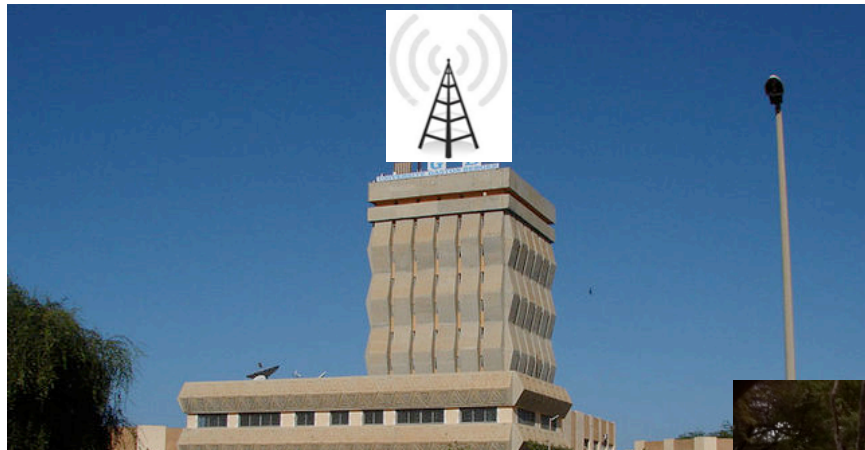
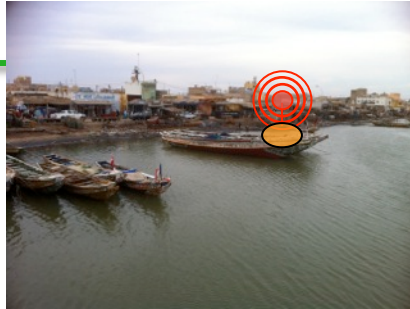

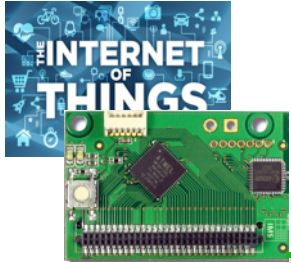

CONCLUSIONS

- ❑ Low-power, long-range (LR) transmission is a break-through technology for IoT and large-scale deployment of wireless (sensor) devices
- ❑ With a large variety of applications, products & actors the low-power WAN (LPWAN) eco-system is becoming mature
- ❑ New technologies will certainly emerge but the LPWAN « philosophy » is now settled firmly: out-of-the-box connectivity is now the standard.
- ❑ Is multi-hop routing for low-power device still interesting in the IoT domain?
- ❑ Mostly driven by industrials, research & development around long-range technologies should also attract the academic research community